

AIRFIT V Vertical

Active Chilled Beams



Introduction

The Barcol-Air AIRFIT V chilled beams have been specifically designed for installation at the perimeter of a building where vertical air discharge is beneficial to offset high perimeter solar and transmission heat loads at the façade. The AIRFIT V series can also be used with one or two way horizontal air discharge for interior zones. The system provides cooling, heating, ventilation and humidity control with minimal noise and with almost no maintenance.

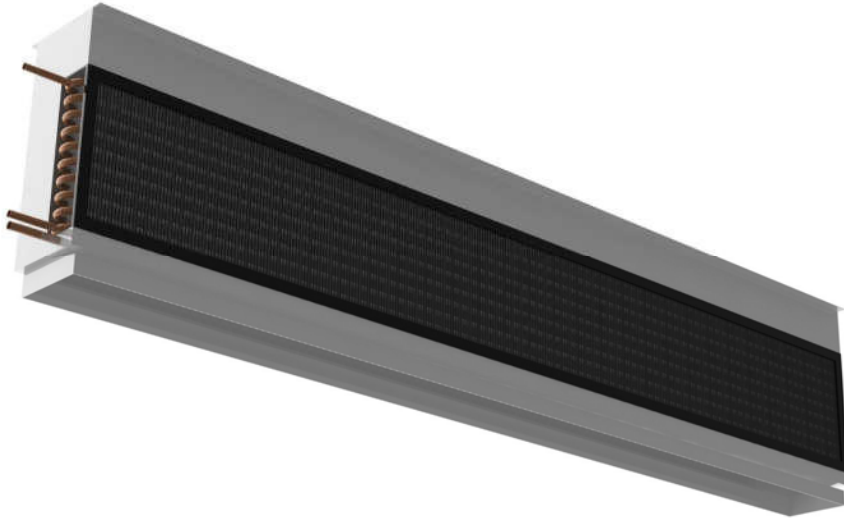

Figure 1: AIRFIT H Active Chilled Beam

System Concept

The principle of the chilled beam system is to use terminal chilled water heat exchangers in the ceiling to offset the room sensible heat loads and primary air to take care of the ventilation and humidity control requirements of the conditioned space as well as to create the induction of room air through the chilled water heat exchanger.

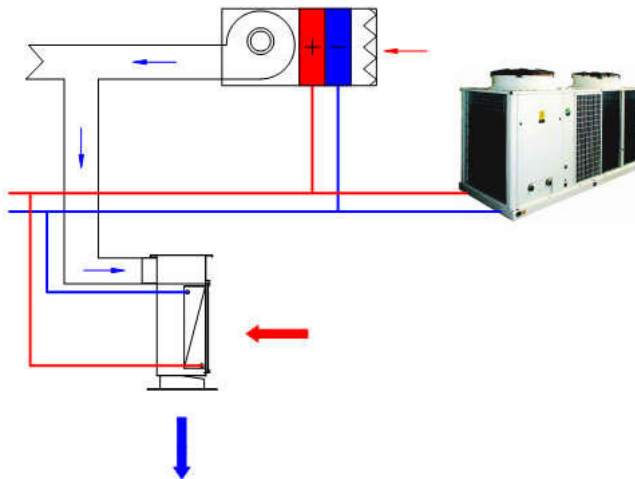

Figure 2: Active Chilled Beam System

This arrangement has several significant advantages. Firstly because air is only needed for ventilation and humidity control the amount of air used by the system can be greatly reduced resulting in large reductions in the amount of energy used to circulate air around the building. Also as the water heat exchanger only handles sensible cooling it can operate dry with higher water temperatures than other systems such as fan coil systems. This means there is no need for condensate drainage systems in the ceiling with all the maintenance and hygiene issues that they bring. Also using higher water temperatures for cooling brings opportunities for further energy savings if dedicated water chillers are used for the high temperature water circuit. Also with the elimination of local fans and motors the system is very quiet and maintenance is reduced.

These advantages make the system highly suitable for applications requiring energy savings, high quality air-conditioning with minimal maintenance.

System Technology

Barcol-Air AIRFIT V active chilled beams integrate the primary air distribution function with the secondary air heat exchange using a proprietary air nozzle technology to induce secondary room air into the unit and through the heat exchanger to be cooled or heated by the chilled or hot water before mixing with the primary air. The resulting mixture of primary air and cooled or heated induced room air is then supplied to the room through optional air diffusers.

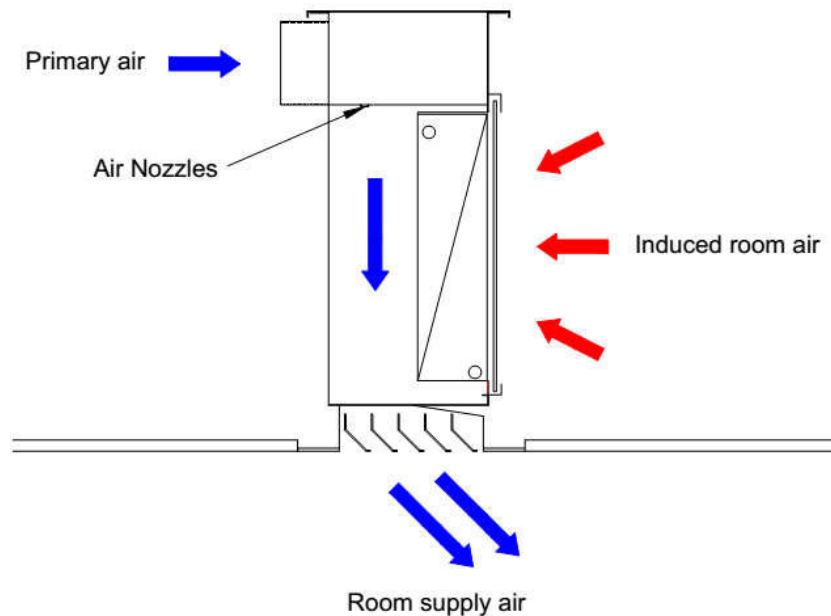

Figure 3: Operating Principle of the Active Chilled Beam

Applications

The AIRFIT V series is suitable for application both in the perimeter zones of a building to offset the facade glazing heat loads and also in the interior zones to offset internal heat loads.

When used at the perimeter of the building the air discharge is usually configured to be downwards adjacent to the perimeter glazing in order to offset the heat load from the glass façade.

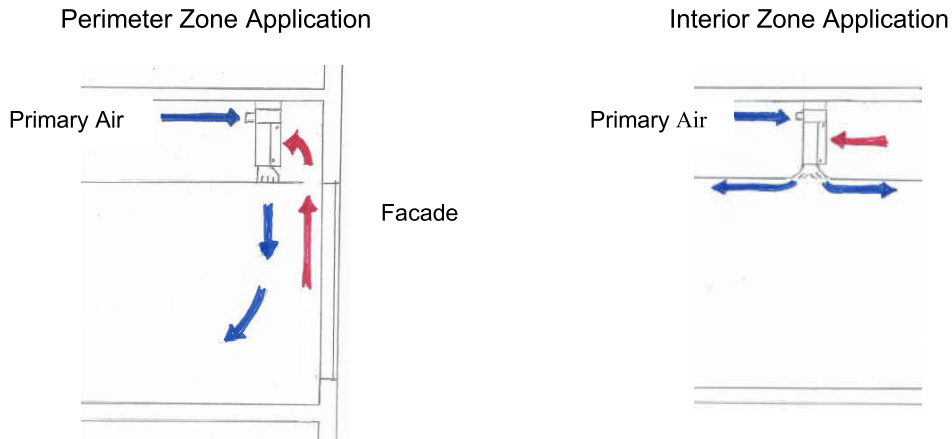

Figure 4: AIRFIT V – Air Distribution

When used for internal zones the air distribution is normally configured to be horizontal across the ceiling using the Coanda effect to increase the air throw of the unit. The air discharge can be one way or two ways depending on the application need.

Optional air diffusers are available to match these different operating configurations.

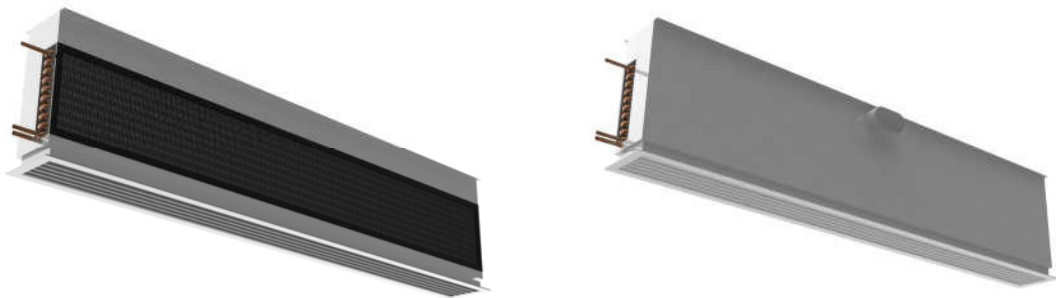

Figure 5: AIRFIT V with optional air diffusers

Product Features

Configuration Choices

Barcol-Air AIRFIT V active chilled beams are configured for horizontal air discharge with 2 pipe water heat exchangers for cooling or heating or 4 pipe heat exchangers for independent cooling and heating water circuits.

Simple Mounting

The units are designed to be suspended from the ceiling slab above a false ceiling and connected to optional supply air diffusers

Different Capacities

The AIRFIT H active chilled beams are available in different widths from 1200mm to 3,000mm to suit various applications and cooling and heating requirements.

Nozzle Technology

The active chilled beams are supplied with proprietary design air nozzles available in eight different nozzle sizes to match the required airflows and the required air distribution arrangement.



Figure 6: High Efficiency Air Nozzles

Ultra Quiet Operation

The air movement through the unit and into the room is created by the induction of room air into the unit due to the low air pressure created around the air nozzles. No electric fans are required to push the air into the room resulting in very low noise operation and more energy savings.

Hygienic Operation

The cooling coil in the unit operates dry with supply and return water temperatures of about 15C to 17C. Therefore there is no need for condensate drain pans or condensate drainage pipe work. This eliminates the health risks due to algae growth in drain pans or the smells and problems which can arise from wet drain pans and drain pipes. Optional drain pans can be provided if required.

Ventilation Humidity and Air Quality Control.

Ventilation, humidity and air quality control is provided by the primary air which is ducted to the active chilled beams from a central air handling unit (AHU). The AHU ensures that the incoming air is dehumidified to control the room humidity for comfort conditions and to eliminate the possibility of any condensation on the cooling coils. The AHU should also include high efficiency air filters to control the room air quality. The AIRFIT V active chilled beams can also be provided with optional air filters if required.

Low Maintenance

With the elimination of air fans and motors and in most cases condensate pans and filters there is almost no maintenance required for the chilled beams. Only the coil requires vacuum cleaning occasionally – typically once per year, to remove any dust.

Dimensions

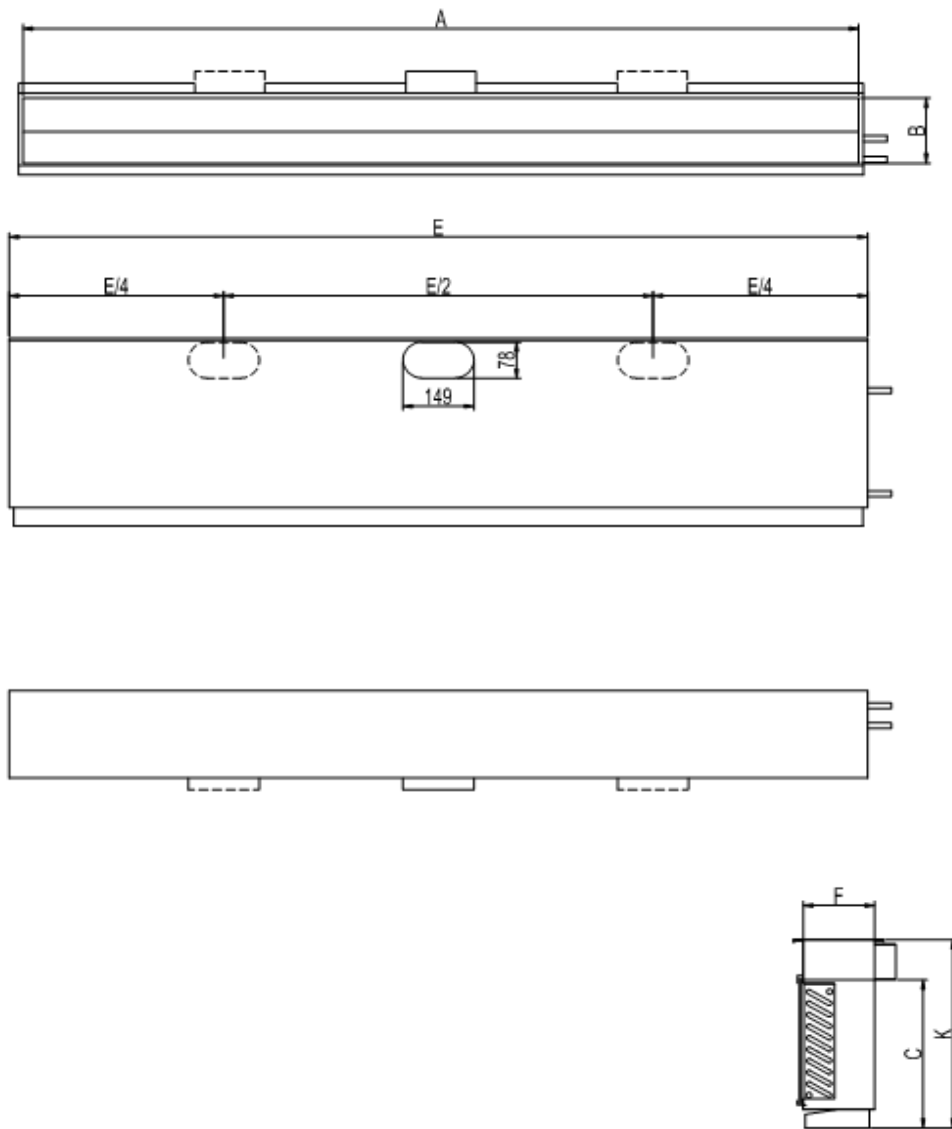

Table1: Dimensional data

AIRFIT V Dimensions (mm)						
Model	900	1200	1500	1800	2400	3000
A	880	1180	1480	1780	2380	2980
B	135	135	135	135	135	135
C	325	325	325	325	325	325
D	1×149×78	1×149×78	1×149×78	1×149×78	2×149×78	2×149×78
E	900	1200	1500	1800	2400	3000
F	149	149	149	149	149	149
K	413	413	413	413	413	413
Operating Weight (kg)	11	15	19	23	30	38

Performance Data

For performance data and selections please contact our sales representative.

Guide Specifications

Barcol-Air AIRFIT V series active chilled beams shall be used to compensate for the external and internal heat loads of the building and shall maintain the thermal comfort in the room within the specified comfort and noise criteria.

Functional description

- Primary air will be supplied by the fresh air handling unit to the chilled beam air plenum box. The primary air shall then pass through the induction nozzles into the mixing section to mix with the induced room air before being distributed into the room from optional air diffusers.
- Induction nozzles shall induce air from the room through the inlet air diffuser and then through the fin and tube water heat exchanger before mixing with the primary air and being supplied to the room. The size and quantity of induction nozzles shall be factory selected and installed to provide the required unit capacity with the specified primary airflow, air inlet pressure and noise level.
- Heat exchangers shall be 2-pipe type for cooling only or cooling/heating changeover systems or 4 pipe type for systems with separate cooling and heating circuits.
- Optional air discharge diffusers shall be available to discharge the supply air either horizontally across the ceiling or vertically for installation adjacent to the façade.

Construction of the chilled beam

- The primary air plenum box shall be manufactured from galvanized sheet steel and shall have one or more oval air spigot connectors to ensure the inlet air velocity does not exceed 2 m/s. The plenum should be internally insulated to prevent condensation if the primary supply air temperature is less than the surrounding air dew point temperature.
- The nozzle plate and chilled beam body shall be manufactured from galvanized steel with a minimum thickness of 0.8mm.
- The heat exchangers shall be made from seamless copper tubes with aluminum fins and shall have 12 or 15 mm diameter water connections depending on unit's size and connections. The heat exchangers shall be suitable to operate at 20 bar working pressure and shall be factory pressure tested at 25 bar pressure.
- Optional supply air diffusers shall be supplied with linear blades finished with polyester powder paint to RAL9010 with 20% gloss or with an alternative finish to be specified.

Dimensions

The active chilled beam height shall be no more than 413 mm and the lengths shall be between 1200mm and 3000mm as indicated in the project schedules. The depth of the chilled beams shall a maximum of 149mm plus air spigot of 40mm.

Installation

The chilled beam shall have 7 mm diameter mounting holes for suspension by 6mm diameter threaded rod or suspension wires.



www.barcolair.net