

NC series

Compact VAV and CAV air volume control terminals



Compact VAV and CAV air volume control terminals

Table of contents

Description	Page
Type designation	1
Technical data	
- General	2
- Specification	3
- Installation instruction	3
Model overview / dimensions	4
Sound data NCOA...	5 - 6
Sound data NCOC...	7 - 8
Sound data NCOG.../NCON...	9 - 10
Sound data NCOJ.../NCOQ...	11 - 12

Compact VAV and CAV air volume control terminals

Type designation
NC.....

Composition type designation:

N - C - O - N - E - B / 200-4-Y / 1 / P

N Position 1: **Product group**

N = air volume control terminals

C Position 2: **Function**

A = single wall, circular volume control terminal
B = double wall, circular volume control terminal
C = compact type
1 = non standard, specify separately

S Position 3: **Leakage rate**

O = low leakage rate VAV terminal
S = Very low leakage rate VAV terminal

O Position 4: **Controls (manufacturer)**

O = without controls
For controls, contact our sales

N Position 5: **Outlet**

A = rectangular outlet
B = circular outlet
C = 4 circular outlets ('Octopus')
G = rectangular outlet and provision for integral hot water reheat coil
J = 4 circular outlets and provision for integral hot water reheat coil
N = rectangular outlet and provision for integral electric reheat coil
Q = 4 circular outlets and provision for integral electric reheat coil
1 = non standard, specify separately

E Position 6: **Reheat coil**

O = without reheat coil
A = 1-row hot water reheat
B = 2-row hot water reheat
D = 4-row hot water reheat
E = 1-stage 230VAC/1-phase electric reheat coil
F = 2-stage 230VAC/1-phase electric reheat coil
G = 3-stage 230VAC/1-phase electric reheat coil
H = 1-stage 400VAC/3-phase electric reheat coil
J = 2-stage 400VAC/3-phase electric reheat coil
1 = non standard, specify separately

B Position 7: **Sensor**

O = not applicable
B = Flo-cross, 2 x 12 point averaging and signal amplifying air flow sensor (standard)
1 = non standard, specify separately

200-4-Y

Position 8 : **Multiple outlets attenuator**

200 = air outlet size
4 = air outlet quantity
Y = with manual regulator
N = without manual regulator
None represent no multiple outlets attenuator

1 Position 10 : **Heating capacity**

1 = Heating capacity 1KW
None = No Heater

P Position 10 : **Finish**

P = powder paint coating
S = SUS304 + Aluminium paint
None = Galvanized steel

Ordering example:

N	C	O	N	E	B	/	1	6	0	R	/	1
See above						Model	Handing	Electric heater		capacity (Watt)		
						100-400	controls	& Heater				

Ordering information:

Standard terminals:

- quantity of terminals
- complete 6/7 digit code
- terminal size or model
- air volume setting (V_{max} , V_{min} etc)
- control handing (standard right side)
- if applicable, electric reheat coil capacity
- supply or return air

Non standard terminals:

- for non standard terminals a full description and / or drawing are requested.

Compact VAV and CAV air volume control terminals

**Technical data
Type (NC.....)**



Application

Compact type NC terminals are pressure independent and suitable for VAV and CAV applications. They have round inlet and rectangular outlet. The terminals are designed for the accurate measurement and control of air volumes courtesy of the patented Flo-Cross airflow sensor. In CAV application, the terminals maintain the required constant airflow independent of the inlet static pressure.

In VAV application, the terminals control the air volume to the room, to meet the cooling and heating load required or to control room or air duct pressure.

The VAV or CAV terminals can be used either for supply or return air applications in new or refurbishment projects. The air terminals can be delivered with an air distribution plenum and an accessory hot water or electric reheat coil.

Features:

- Pressure independent control functions.
- Volume control range 100% to 10%.
- Low pressure loss over the terminal.
- Factory fitted air distribution plenum with accessory hot water or electric reheat coil.
- Oval shaped damper blade for linear control characteristics.
- Low leakage damper.
- Low noise level.
- Suitable for all control functions VAV, CAV, shut-off to maximise system energy savings.

- Flo-Cross, 2 x 12 points averaging and signal amplification air flow sensor, ensuring air flow measurement accuracy of better than $\pm 2.5\%$ in its operating range.
- Maintenance free.

Technical information

Casing:

Air-tight construction made of galvanized sheet steel with low casing leakage rate. Casing air leakage Class C according to Standard EN1751.

Insulation:

The rectangular discharge section is internally insulated to reduce heat transfer & radiated noise.

Damper:

Damper blade: made of steel, sandwich construction with twin blades and a neoprene gasket with low leakage. Closed blade damper air leakage, Class 4 according to standard EN1751, except diameters 100 and 125 are class 3.

Damper shaft: aluminum, 12mm diameter with nylon bearings

Flo-Cross:

Extruded aluminium construction with nylon core and feet

Distribution plenum:

Made of galvanised sheet steel with internal isolation. Plenum with standard rectangular outlet construction or with 1 to 7 circular outlets. Outlet spigots are made of galvanised steel and optionally can be provided with adjustable volume control dampers.

Reheat coil:

Choice of 1, 2 or 4-row hot water reheat coil or electric reheat coil (220-240VAC/1-phase or 380-415VAC/3-phase).

Controls:

Suitable for use with pneumatic, analogue electronic or DDC controllers. Controls can be factory fitted, wired and calibrated. Controls enclosure made from galvanised sheet steel can be provided as an option.

Delivery format:

Delivery format:

- The VAV or CAV terminal will be supplied as a single mounting assembly. Optional ordered distribution plenum, reheat coil and/or controls are factory fitted, wired and calibrated. The terminal can be directly installed and commissioned when delivered to site.
- Controls location and hot water or electric connections are as standard fitted on the right hand side of the terminal when looking in the direction of the airflow. On request, the terminal can be delivered with connections on the left hand side.
- When terminals are ordered with controls, these will be factory fitted, wired and calibrated upon request.

Compact VAV and CAV air volume control terminals

Technical data
Type (NC.....)



Specify as:

Example:

Supply and install, variable air volume terminals with distribution plenum and 4 circular outlets, constructed from galvanized sheet steel. The casing leakage rate shall be class C according to standard EN1751. The closed blade damper air leakage shall be class 4 according to standard EN1751 except diameters 100 and 125 shall be class 3. The VAV terminals shall have oval shaped damper blade with neoprene gasket and an aluminium damper shaft with self lubricating nylon bearings.

A Flo-Cross centre averaging airflow sensor with at least 2x12 test points and amplified signal, with a sensing accuracy better than $\pm 2.5\%$ shall control the air flow. The terminals shall be supplied with 1 row hot water reheat coil. The controller shall be I/A Series, DDC controller: LonMark compatible, type MNL-V2RVx or BACnet, type MNB-V2.

Controls must be factory fitted, wired and calibrated according to the following requirements:

Maximum air volume 250 l/s
Minimum air volume 60 l/s
Minimum air volume 120 l/s (in case of reheat)
Terminal inlet size 200 mm diameter
Max. pressure loss 38 Pa
Max. discharge sound index < NC30 @250Pa Δp
Max. radiated sound index < NC30

@250Pa Δp

Ordering example: type - model - handing= NCDJAB - 200R

Manufacturer: Barcol-Air

Installation Instructions

The Barcol-Air VAV terminals shall be installed using at least two support channels, with anti-vibration rubber under the terminal (as shown in the drawing below). Each of these channels shall be fixed with two threaded rods to the ceiling slab above. Alternatively 4 support brackets can be used for suspending the units.

The installation method:

1. Shall prevent the body of the VAV terminal from high mechanical tension, which could damage the construction and performance of the terminal.
2. Shall prevent torsion on the VAV terminals, which could cause malfunction of the damper blades.

3. Provides some flexibility to the final location of the VAV terminals.
4. Use at least one diameter length of straight air duct of the same cross section as the VAV inlet to ensure the flow sensor accuracy.
5. Additional manual volume control dampers (VCD's) should not be installed before the unit inlet.
6. All connections shall be thermally isolated.
7. Pressure sensing tubes for the Flo-Cross airflow sensor shall not be "kinked" or otherwise obstructed by external duct insulation.

See drawing below.

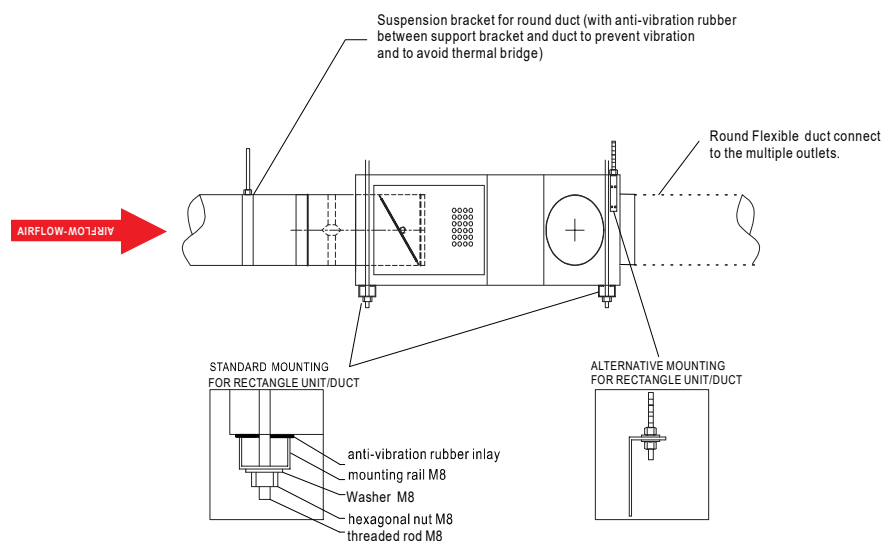

Compact VAV and CAV air volume control terminals

**Technical data:
Type (NC.....)**

NC series base unit

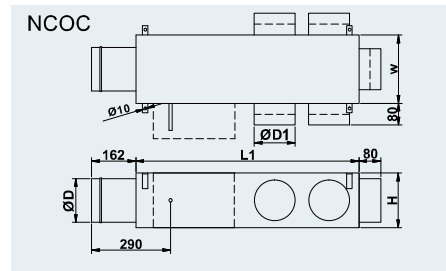
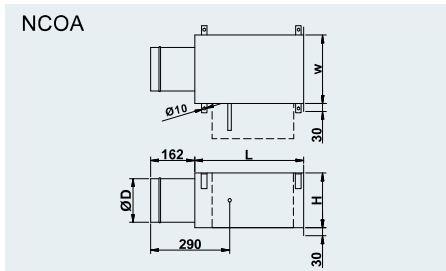

NC series with Hot Water Reheat

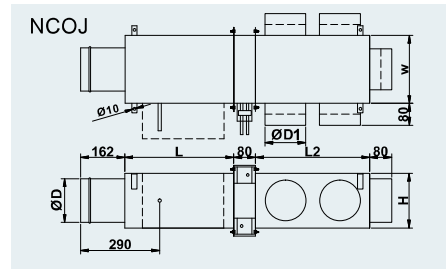
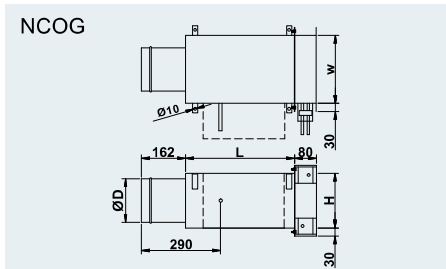

NC series with Electric Reheat

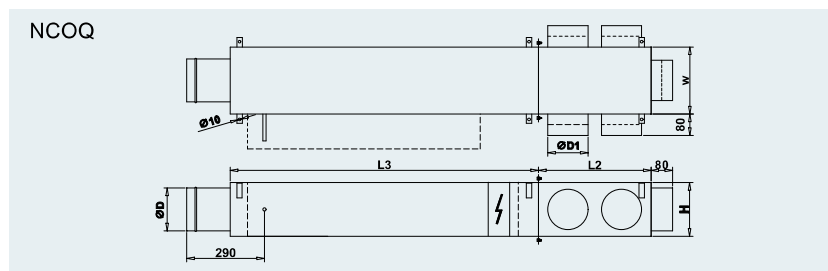
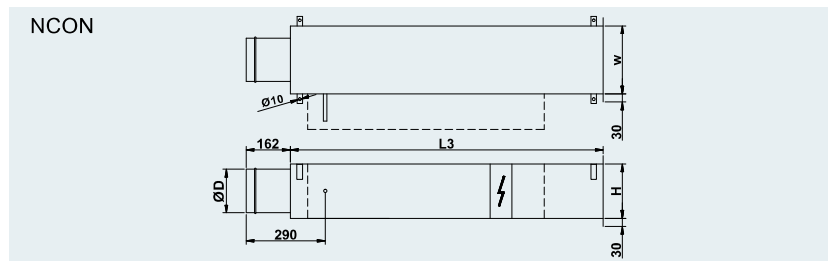

Dimensions NC terminals

Model	100	125	160	200	250	315	355	400
W	250	250	250	300	350	400	500	550
H	200	200	200	250	300	365	405	450
L	400	400	400	400	400	500	500	500
ØD	98	123	158	198	248	313	353	398
ØD1	148	148	148	198	248	248	248	248
L1	820	820	820	920	1020	1120	1120	1120
L2	420	420	420	520	620	620	620	620
L3	740	740	740	740	740	840	840	840

All dimensions in mm.
* = Installed length.
** = Size varies with a 1-2-row or 4-row hot water reheat coil.

Other dimensions are available upon request.

Compact VAV and CAV air volume control terminals

Type NCOA

Sound data $\Delta p = 125 \text{ Pa}$

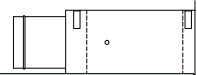

Model	data referring to inlet spigot					$\Delta p = 125 \text{ Pa}$																		
						discharge sound						radiated sound												
	Velocity		air volume			min. ΔP	L_w in dB/Oct. (re 1pW)						Lp values			L_w in dB/Oct. (re 1pW)						Lp values		
							125 Hz	250 Hz	500 Hz	1000 Hz	2000 Hz	4000 Hz	dB(A)	NC	NR	125 Hz	250 Hz	500 Hz	1000 Hz	2000 Hz	4000 Hz	dB(A)	NC	NR
m/s	l/s	CFM	m ³ /h	Pa	DB						dB													
100	2	15	31	53	2	43	44	40	38	34	22	--	--	--	-	-	-	-	-	-	-	--	--	--
	4	29	62	106	8	49	50	46	44	40	29	24	--	20	22	-	-	-	-	-	-	--	--	--
	6	44	94	160	17	53	54	51	48	44	34	28	22	24	26	20	-	-	-	-	18	--	--	--
	8	59	125	213	30	57	58	54	52	49	39	31	26	28	29	23	19	19	19	19	21	--	--	--
	10	74	156	266	47	59	61	58	55	52	43	34	29	31	32	26	22	21	21	23	23	--	--	--
125	2	23	49	84	2	40	43	40	39	34	25	--	--	--	-	-	-	-	-	-	-	--	--	--
	4	47	99	168	7	47	49	46	45	40	31	23	--	--	23	18	-	-	-	-	-	--	--	--
	6	70	149	253	16	52	54	51	49	44	36	27	21	24	27	22	19	18	-	-	19	--	--	--
	8	94	198	337	28	56	58	55	53	48	40	31	25	28	30	25	22	21	20	22	22	--	--	--
	10	117	248	421	44	59	61	58	56	51	44	34	29	31	33	28	25	23	22	24	24	--	--	--
160	2	39	82	139	2	39	41	40	38	37	32	--	--	--	18	-	-	-	-	-	-	--	--	--
	4	78	164	279	7	47	48	46	44	41	36	22	--	--	25	20	19	-	-	-	-	--	--	--
	6	116	246	418	15	52	52	50	49	44	39	26	--	22	29	24	23	20	18	20	20	--	--	--
	8	155	328	558	26	56	56	54	52	48	42	30	24	26	32	27	26	23	21	23	23	--	--	--
	10	194	410	697	41	60	60	58	56	51	45	34	28	30	34	29	28	25	23	25	25	--	--	--
200	2	61	129	219	2	39	34	37	34	30	23	--	--	--	19	-	-	-	-	-	-	--	--	--
	4	122	258	439	6	48	44	46	42	37	31	20	--	--	26	22	21	18	-	-	-	--	--	--
	6	183	387	658	14	54	51	52	47	42	36	26	--	20	30	26	25	22	20	21	21	--	--	--
	8	244	516	878	25	58	55	56	51	46	40	31	23	25	33	29	28	25	22	24	24	--	--	--
	10	305	645	1097	39	61	59	60	54	50	43	34	27	30	35	31	30	27	25	26	26	--	--	--
250	2	96	203	345	1	41	43	42	39	34	30	--	--	--	19	-	-	-	-	-	-	--	--	--
	4	192	406	690	6	50	51	50	45	40	35	25	--	20	26	21	21	18	-	-	-	--	--	--
	6	288	609	1035	13	56	56	55	50	44	39	30	23	26	30	25	25	22	20	21	21	--	--	--
	8	383	812	1380	23	60	60	59	53	47	43	34	28	30	33	28	28	25	23	24	24	--	--	--
	10	479	1015	1725	36	63	63	62	56	50	45	37	32	34	35	31	31	27	25	26	26	--	--	--
315	2	153	324	550	1	42	45	41	41	38	33	--	--	--	21	18	18	-	-	-	-	--	--	--
	4	306	648	1101	5	52	52	48	47	43	38	26	--	21	28	25	25	22	18	19	19	--	--	--
	6	459	971	1651	12	58	57	54	52	48	42	31	24	27	32	29	29	26	22	23	23	--	--	--
	8	612	1295	2202	22	63	61	58	56	52	46	35	29	31	35	32	32	29	25	26	26	--	--	--
	10	764	1619	2752	34	67	64	62	59	55	50	39	34	35	38	34	34	31	27	28	28	--	--	--
355	2	195	412	701	1	42	52	45	45	40	38	24	--	21	22	19	19	-	-	-	-	--	--	--
	4	389	824	1401	5	53	56	51	50	43	42	29	24	26	29	26	26	23	18	20	20	--	--	--
	6	584	1236	2102	12	59	60	56	54	46	45	33	28	30	33	30	30	27	23	24	24	--	--	--
	8	779	1649	2803	21	64	63	60	57	50	48	37	32	33	36	33	33	30	25	27	27	--	--	--
	10	973	2061	3503	33	68	66	64	61	53	52	41	36	37	38	35	35	32	28	29	29	--	--	--
400	2	248	524	891	1	43	54	46	46	42	36	26	21	24	22	19	19	-	-	-	-	--	--	--
	4	495	1049	1783	5	54	58	52	51	45	40	31	26	28	29	26	26	24	19	20	20	--	--	--
	6	743	1573	2674	11	60	62	57	55	48	43	35	30	32	33	30	30	28	23	24	24	--	--	--
	8	990	2097	3565	20	65	65	61	58	52	46	39	34	36	36	33	33	31	26	27	27	--	--	--
	10	1238	2621	4456	32	69	68	65	62	55	50	42	37	39	39	36	36	33	28	29	29	--	--	--

- Sound data is determined in a reverberation room at an independent sound laboratory, according to ISO3741 and ISO 5135 standards.
- L_w in dB/Oct. (re 1pW) are sound power levels for discharge sound and case radiated sound. Figures less than 17 dB are indicated by "--".
- The discharge sound pressure levels are determined with the assumptions as mentioned in table 1 for downstream ductwork including a diffuser with insulated plenum box.
- The radiated sound pressure levels are determined with the assumptions as mentioned in table 1 for ceiling plenum and suspended ceiling absorption.
- Lp values are including a room absorption of 10 dB/Oct.

- DB(A), NC and NR index figures are sound pressure levels. Figures less than 20 are indicated by "--".
- \square p is total pressure drop across VAV air volume control terminal with damper fully open.
- For insertion loss see table 2.
- For non standard applications and/or selections, please contact our technical staff.

Table 1 : Assumptions for additional attenuation

Hz	125	250	500	1K	2K	4K
Discharge (dB)	5	10	20	30	30	25
Radiated (dB)	2	5	10	15	15	20

Table 2: Insertion Loss

Model	125	250	500	1K	2K	4K	Hz
100	9	10	11	13	15	15	dB
125	8	9	10	12	14	14	dB
160	8	9	10	12	14	14	dB
200	8	8	9	11	13	13	dB
250	7	8	9	11	13	13	dB
315	7	8	9	11	13	13	dB
355	7	8	9	11	13	13	dB
400	7	8	9	11	13	13	dB

Compact VAV and CAV air volume control terminals

Type NCOA

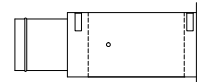

Sound data $\Delta p = 250 \text{ Pa}$

Model	data referring to inlet spigot				min. ΔP	$\Delta p = 250 \text{ Pa}$																	
						discharge sound						radiated sound											
	Velocity		air volume			L_w in dB/Oct. (re 1pW)						Lp values			L_w in dB/Oct. (re 1pW)						Lp values		
						125 Hz	250 Hz	500 Hz	1000 Hz	2000 Hz	4000 Hz	dB (A)	NC	NR	125 Hz	250 Hz	500 Hz	1000 Hz	2000 Hz	4000 Hz	dB (A)	NC	NR
m/s	l/s	CFM	m ³ /h	Pa	dB						dB												
100	2	15	31	53	2	45	48	45	43	40	29	21	--	--	21	-	-	-	-	-	--	--	--
	4	29	62	106	8	51	53	51	48	45	35	27	20	23	28	22	18	-	-	18	--	--	--
	6	44	94	160	17	55	57	54	52	49	40	31	25	27	32	26	22	20	20	22	--	--	--
	8	59	125	213	30	58	60	57	55	53	44	34	28	31	35	29	25	23	23	25	--	--	--
	10	74	156	266	47	60	63	60	57	56	47	36	32	33	38	32	28	25	25	27	--	--	--
125	2	23	49	84	2	43	47	46	43	40	33	20	--	--	22	17	-	-	-	-	--	--	--
	4	47	99	168	7	50	53	51	49	45	38	26	20	23	29	24	21	18	-	19	--	--	--
	6	70	149	253	16	54	57	55	53	48	41	30	25	27	33	28	25	22	21	23	--	--	--
	8	94	198	337	28	58	60	58	56	51	45	34	29	31	36	31	28	25	24	26	--	--	--
	10	117	248	421	44	61	63	61	58	54	48	37	32	34	39	34	31	27	26	28	--	--	--
160	2	39	82	139	2	42	47	46	44	43	40	20	--	--	24	19	18	-	-	-	--	--	--
	4	78	164	279	7	50	53	52	50	47	43	26	20	23	31	26	25	20	18	20	--	--	--
	6	116	246	418	15	55	57	55	54	50	46	31	24	27	35	30	29	24	22	24	--	--	--
	8	155	328	558	26	59	60	59	57	53	48	34	28	30	38	33	32	27	25	27	--	--	--
	10	194	410	697	41	62	63	61	59	55	50	37	32	33	40	35	34	29	27	29	--	--	--
200	2	61	129	219	2	43	38	41	39	36	30	--	--	--	25	21	20	-	-	-	--	--	--
	4	122	258	439	6	52	49	50	47	43	37	24	--	--	32	28	27	22	19	21	--	--	--
	6	183	387	658	14	57	55	56	51	47	42	30	22	24	36	32	31	26	23	25	--	--	--
	8	244	516	878	25	61	59	60	55	51	45	34	27	29	39	35	34	29	26	28	--	--	--
	10	305	645	1097	39	64	63	63	58	54	48	38	31	33	41	37	36	31	29	30	--	--	--
250	2	96	203	345	1	44	47	46	44	41	37	21	--	--	25	20	20	-	-	-	--	--	--
	4	192	406	690	6	53	55	54	50	46	42	29	23	25	32	27	27	22	20	21	--	--	--
	6	288	609	1035	13	59	60	59	54	50	46	34	28	31	36	31	31	26	24	25	--	--	--
	8	383	812	1380	23	63	64	62	57	53	48	38	33	35	39	34	34	29	27	28	--	--	--
	10	479	1015	1725	36	66	67	65	60	55	51	41	36	38	41	37	37	31	29	30	--	--	--
315	2	153	324	550	1	45	50	45	46	45	40	23	--	20	27	24	24	19	-	-	--	--	--
	4	306	648	1101	5	54	56	52	52	50	44	30	24	26	34	31	31	26	22	23	--	--	--
	6	459	971	1651	12	60	60	57	56	53	48	34	28	31	38	35	35	30	26	27	--	--	--
	8	612	1295	2202	22	65	64	61	59	56	51	38	33	34	41	38	38	33	29	30	--	--	--
	10	764	1619	2752	34	69	67	64	62	59	54	41	36	37	44	40	40	35	31	32	22	--	--
355	2	195	412	701	1	45	57	50	51	47	47	29	24	27	28	25	25	20	-	-	--	--	--
	4	389	824	1401	5	55	61	56	55	50	49	33	29	31	35	32	32	27	22	24	--	--	--
	6	584	1236	2102	12	61	64	60	58	52	51	37	32	34	39	36	36	31	26	28	--	--	--
	8	779	1649	2803	21	66	66	63	61	55	54	40	35	37	42	39	39	34	29	31	20	--	--
	10	973	2061	3503	33	70	69	66	64	57	56	43	38	39	44	41	41	36	32	33	23	--	--
400	2	248	524	891	1	46	59	51	52	49	45	31	27	29	28	25	25	21	-	17	--	--	--
	4	495	1049	1783	5	56	63	57	56	52	47	35	31	33	35	32	32	28	23	24	--	--	--
	6	743	1573	2674	11	62	66	61	59	54	49	39	35	36	39	36	36	32	27	28	--	--	--
	8	990	2097	3565	20	67	68	64	62	57	52	42	38	39	42	39	39	35	30	31	21	--	--
	10	1238	2621	4456	32	71	71	67	65	59	54	45	41	42	45	42	42	37	32	33	23	--	--

1. Sound data is determined in a reverberation room at an independent sound laboratory, according to ISO3741 and ISO 5135 standards.
2. L_w in dB/Oct. (re 1pW) are sound power levels for discharge sound and case radiated sound. Figures less than 17 dB are indicated by "--".
3. The discharge sound pressure levels are determined with the assumptions as mentioned in table 1 for downstream ductwork including a diffuser with insulated plenum box.
4. The radiated sound pressure levels are determined with the assumptions as mentioned in table 1 for ceiling plenum and suspended ceiling absorption.

5. Lp values are including a room absorption of 10 dB/Oct.
6. DB(A), NC and NR index figures are sound pressure levels. Figures less than 20 are indicated by "--".
7. Δp is total pressure drop across VAV air volume control terminal with damper fully open.
8. For insertion loss see table 2.
9. For non standard applications and/or selections, please contact our technical staff.

Table 1: Assumptions for additional attenuation

Hz	125	250	500	1K	2K	4K
Discharge (dB)	5	10	20	30	30	25
Radiated (dB)	2	5	10	15	15	20

Table 2: Insertion Loss

Model	125	250	500	1K	2K	4K	Hz
100	9	10	11	13	15	15	dB
125	8	9	10	12	14	14	dB
160	8	9	10	12	14	14	dB
200	8	8	9	11	13	13	dB
250	7	8	9	11	13	13	dB
315	7	8	9	11	13	13	dB
355	7	8	9	11	13	13	dB
400	7	8	9	11	13	13	dB

Compact VAV and CAV air volume control terminals

Type NCOC

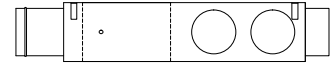

Sound data $\Delta p = 250 \text{ Pa}$

Model	data referring to inlet spigot				min. ΔP	$\Delta p = 250 \text{ Pa}$																	
						discharge sound						radiated sound											
	air volume					L_w in dB/Oct. (re 1pW)						Lp values			L_w in dB/Oct. (re 1pW)						Lp values		
						125 Hz	250 Hz	500 Hz	1000	2000	4000	dB(A)	NC	NR	125 Hz	250 Hz	500 Hz	1000	2000	4000	dB(A)	NC	NR
m/s	L/s	CFM	m ³ /h	Pa	dB						dB												
100	2	15	31	53	2	36	36	27	23	18	-	--	--	21	-	-	-	-	-	--	--	--	
	4	29	62	106	8	42	41	33	28	23	-	--	--	28	22	18	-	-	18	--	--	--	
	6	44	94	160	17	46	45	36	32	27	-	--	--	32	26	22	20	20	22	--	--	--	
	8	59	125	213	30	49	48	39	35	31	20	22	--	--	35	29	25	23	23	25	--	--	--
	10	74	156	266	47	51	51	42	37	34	23	25	--	21	38	32	28	25	25	27	--	--	--
125	2	23	49	84	2	34	35	28	23	18	-	--	--	22	17	-	-	-	-	--	--	--	
	4	47	99	168	7	41	41	33	29	23	-	--	--	29	24	21	18	-	19	--	--	--	
	6	70	149	253	16	45	45	37	33	26	17	--	--	33	28	25	22	21	23	--	--	--	
	8	94	198	337	28	49	48	40	36	29	21	22	--	--	36	31	28	25	24	26	--	--	--
	10	117	248	421	44	52	51	43	38	32	24	25	--	21	39	34	31	27	26	28	--	--	--
160	2	39	82	139	2	33	35	28	24	21	-	--	--	24	19	18	-	-	-	--	--	--	
	4	78	164	279	7	41	41	34	30	25	19	--	--	31	26	25	20	18	20	--	--	--	
	6	116	246	418	15	46	45	37	34	28	22	--	--	35	30	29	24	22	24	--	--	--	
	8	155	328	558	26	50	48	41	37	31	24	22	--	--	38	33	32	27	25	27	--	--	--
	10	194	410	697	41	53	51	43	39	33	26	25	--	21	40	35	34	29	27	29	--	--	--
200	2	61	129	219	2	34	26	23	19	-	-	--	--	25	21	20	-	-	-	--	--	--	
	4	122	258	439	6	43	37	32	27	21	-	--	--	32	28	27	22	19	21	--	--	--	
	6	183	387	658	14	48	43	38	31	25	18	--	--	36	32	31	26	23	25	--	--	--	
	8	244	516	878	25	52	47	42	35	29	21	23	--	--	39	35	34	29	26	28	--	--	--
	10	305	645	1097	39	55	51	45	38	32	24	27	--	21	41	37	36	31	29	30	--	--	--
250	2	96	203	345	1	35	35	28	24	19	-	--	--	25	20	20	-	-	-	--	--	--	
	4	192	406	690	6	44	43	36	30	24	18	--	--	32	27	27	22	20	21	--	--	--	
	6	288	609	1035	13	50	48	41	34	28	22	--	--	36	31	31	26	24	25	--	--	--	
	8	383	812	1380	23	54	52	44	37	31	24	26	--	22	39	34	34	29	27	28	--	--	--
	10	479	1015	1725	36	57	55	47	40	33	27	29	22	25	41	37	37	31	29	30	--	--	--
315	2	153	324	550	1	39	42	27	26	23	-	--	--	27	24	24	19	-	-	--	--	--	
	4	306	648	1101	5	48	48	34	32	28	20	22	--	34	31	31	26	22	23	--	--	--	
	6	459	971	1651	12	54	52	39	36	31	24	27	--	38	35	35	30	26	27	--	--	--	
	8	612	1295	2202	22	59	56	43	39	34	27	31	23	26	41	38	38	33	29	30	--	--	--
	10	764	1619	2752	34	63	59	46	42	37	30	34	28	29	44	40	40	35	31	32	22	--	--
355	2	195	412	701	1	39	49	32	31	25	23	21	--	28	25	25	20	-	-	--	--	--	
	4	389	824	1401	5	49	53	38	35	28	25	25	20	23	35	32	32	27	22	24	--	--	--
	6	584	1236	2102	12	55	56	42	38	30	27	29	23	26	39	36	36	31	26	28	--	--	--
	8	779	1649	2803	21	60	58	45	41	33	30	32	26	28	42	39	39	34	29	31	20	--	--
	10	973	2061	3503	33	64	61	48	44	35	32	35	30	31	44	41	41	36	32	33	23	--	--
400	2	248	524	891	1	40	51	33	32	27	21	23	--	28	25	25	21	-	17	--	--	--	
	4	495	1049	1783	5	50	55	39	36	30	23	27	22	25	35	32	32	28	23	24	--	--	--
	6	743	1573	2674	11	56	58	43	39	32	25	31	25	28	39	36	36	32	27	28	--	--	--
	8	990	2097	3565	20	61	60	46	42	35	28	34	28	31	42	39	39	35	30	31	21	--	--
	10	1238	2621	4456	32	65	63	49	45	37	30	37	31	33	45	42	42	37	32	33	23	--	--

1. Sound data is determined in a reverberation room at an independent sound laboratory, according to ISO3741 and ISO 5135 standards.
2. L_w in dB/Oct. (re 1pW) are sound power levels for discharge sound and case radiated sound. Figures less than 17 dB are indicated by "-".
3. The discharge sound pressure levels are determined with the assumptions as mentioned in table 1 for downstream ductwork including a diffuser with insulated plenum box.
4. The radiated sound pressure levels are determined with the assumptions as mentioned in table 1 for ceiling plenum and suspended ceiling absorption.

5. Lp values are including a room absorption of 10 dB/Oct.
6. dB(A), NC and NR index figures are sound pressure levels. Figures less than 20 are indicated by "-".
7. Δp is total pressure drop across VAV air volume control terminal with damper fully open.
8. For insertion loss see table 2.
9. For non standard applications and/or selections, please contact our technical staff.

Table 1: Assumptions for additional attenuation

Hz	125	250	500	1K	2K	4K
Discharge (dB)	5	10	20	30	30	25
Radiated (dB)	2	5	10	15	15	20

Table 2: Insertion Loss

Model	125	250	500	1K	2K	4K	Hz
100	13	17	23	26	28	30	dB
125	12	15	22	25	27	29	dB
160	12	15	22	25	27	29	dB
200	11	15	21	24	26	28	dB
250	11	15	21	24	26	28	dB
315	8	11	21	24	26	26	dB
355	8	11	21	24	26	26	dB
400	8	11	21	24	26	26	dB

Compact VAV and CAV air volume control terminals

Type NCOG NCON

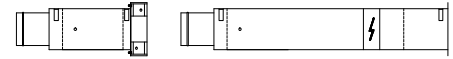

Sound data $\Delta p = 250 \text{ Pa}$

Model	data referring to inlet spigot					$\Delta p = 250 \text{ Pa}$																																																																																																																	
						discharge sound						radiated sound																																																																																																											
	Velocity		air volume			min. ΔP	L_w in dB/Oct. (re 1pW)					Lp values			L_w in dB/Oct. (re 1pW)					Lp values																																																																																																			
							125 Hz	250 Hz	500 Hz	1000	2000	4000	dB (A)	NC	NR	125 Hz	250 Hz	500 Hz	1000	2000	4000	dB (A)	NC	NR																																																																																															
m/s	l/s	CFM	m³/h	Pa	dB						dB																																																																																																												
100	2	15	31	53	3	40	41	34	31	28	-	--	--	--	21	-	-	-	-	-	--	--	--	4	29	62	106	11	46	46	39	36	33	21	20	--	--	28	22	18	-	-	18	--	--	--	6	44	94	160	24	50	50	42	39	37	25	23	--	--	32	26	22	20	20	22	--	--	--	8	59	125	213	43	52	53	45	42	40	29	26	--	22	35	29	25	23	23	25	--	--	--	10	74	156	266	67	54	55	47	44	43	32	28	22	25	38	32	28	25	25	27	--	--	--				
	125	2	23	49	84	3	38	40	34	32	28	19	--	--	--	22	17	-	-	-	-	--	--	--	4	47	99	168	10	45	46	39	37	33	24	--	--	--	29	24	21	18	-	19	--	--	--	6	70	149	253	23	49	50	43	40	36	27	23	--	--	33	28	25	22	21	23	--	--	--	8	94	198	337	40	52	53	46	43	39	30	26	--	22	36	31	28	25	24	26	--	--	--	10	117	248	421	63	55	55	48	45	41	33	29	23	25	39	34	31	27	26	28	--	--	--			
		160	2	39	82	139	2	38	40	34	32	32	26	--	--	--	24	19	18	-	-	-	--	--	--	4	78	164	279	9	45	46	40	38	35	29	--	--	--	31	26	25	20	18	20	--	--	--	6	116	246	418	21	50	49	43	41	38	31	23	--	--	35	30	29	24	22	24	--	--	--	8	155	328	558	38	53	52	46	44	40	33	26	--	22	38	33	32	27	25	27	--	--	--	10	194	410	697	59	56	55	48	46	42	35	29	22	25	40	35	34	29	27	29	--	--	--		
			200	2	61	129	219	2	39	32	29	27	24	-	--	--	--	25	21	20	-	-	-	--	--	--	4	122	258	439	9	47	41	38	35	31	23	--	--	--	32	28	27	22	19	21	--	--	--	6	183	387	658	21	52	47	43	39	35	27	23	--	--	36	32	31	26	23	25	--	--	--	8	244	516	878	38	55	51	47	42	38	30	27	--	--	41	39	35	34	29	26	28	--	--	--	10	305	645	1097	59	58	54	50	44	41	33	30	22	24	41	37	36	31	29	30	--	--	--
				250	2	96	203	345	2	40	41	34	32	29	23	--	--	--	25	20	20	-	-	-	--	--	--	4	192	406	690	9	48	48	42	38	34	28	22	--	--	32	27	27	22	20	21	--	--	--	6	288	609	1035	21	53	53	46	42	37	31	27	20	23	36	31	31	26	24	25	--	--	--	8	383	812	1380	38	57	56	49	45	40	34	30	23	26	39	34	34	29	27	28	--	--	--	10	479	1015	1725	59	60	59	52	47	42	36	33	27	29	41	37	37	31	29	30	--	--	--
315	2				153	324	550	2	43	47	34	35	33	26	20	--	--	27	24	24	19	-	-	--	--	--	4	306	648	1101	9	52	53	40	40	37	30	26	20	23	34	31	31	26	22	23	--	--	--	6	459	971	1651	21	58	57	45	43	40	33	31	24	27	38	35	35	30	26	27	--	--	--	8	612	1295	2202	38	62	60	48	46	43	36	34	28	30	41	38	38	33	29	30	--	--	--	10	764	1619	2752	59	66	63	51	49	46	39	37	32	33	44	40	40	35	31	32	22	--	--	--
	355	2			195	412	701	2	43	54	38	39	35	33	26	21	24	28	25	25	20	-	-	--	--	--	4	389	824	1401	9	53	58	44	43	38	35	30	25	28	35	32	32	27	22	24	--	--	--	6	584	1236	2102	21	59	60	48	46	40	37	33	28	31	39	36	36	31	26	28	--	--	--	8	779	1649	2803	38	63	63	51	48	42	39	36	31	33	42	39	39	34	29	31	20	--	--	--	10	973	2061	3503	59	67	65	53	51	44	41	39	34	35	44	41	41	36	32	33	23	--	--
		400	2		248	524	891	2	44	56	39	40	37	31	28	24	26	28	25	25	21	-	17	--	--	--	4	495	1049	1783	9	54	60	45	44	40	33	32	28	30	35	32	32	28	23	24	--	--	--	6	743	1573	2674	21	60	62	49	47	42	35	35	31	33	39	36	36	32	27	28	--	--	--	8	990	2097	3565	38	64	65	52	49	44	37	38	33	35	42	39	39	35	30	31	21	--	--	--	10	1238	2621	4456	59	68	67	54	52	46	39	41	36	37	45	42	42	37	32	33	23	--	--

1. Sound data is determined in a reverberation room at an independent sound laboratory, according to ISO3741 and ISO 5135 standards.
2. L_w in dB/Oct. (re 1pW) are sound power levels for discharge sound and case radiated sound. Figures less than 17 dB are indicated by "--".
3. The discharge sound pressure levels are determined with the assumptions as mentioned in table 1 for downstream ductwork including a diffuser with insulated plenum box.
4. The radiated sound pressure levels are determined with the assumptions as mentioned in table 1 for ceiling plenum and suspended ceiling absorption.

5. Lp values are including a room absorption of 10 dB/Oct.
6. dB(A), NC and NR index figures are sound pressure levels. Figures less than 20 are indicated by "--".
7. Δp is total pressure drop across VAV air volume control terminal with damper fully open.
8. For insertion loss see table 2.
9. For non standard applications and/or selections, please contact our technical staff.

Table 1: Assumptions for additional attenuation

Hz	125	250	500	1K	2K	4K
Discharge (dB)	5	10	20	30	30	25
Radiated (dB)	2	5	10	15	15	20

Table 2: Insertion Loss

Model	125	250	500	1K	2K	4K	Hz
100	9	10	11	13	15	15	dB
125	8	9	10	12	14	14	dB
160	8	9	10	12	14	14	dB
200	8	8	9	11	13	13	dB
250	7	8	9	11	13	13	dB
315	7	8	9	11	13	13	dB
355	7	8	9	11	13	13	dB
400	7	8	9	11	13	13	dB

Compact VAV and CAV air volume control terminals

Type **NCOJ** **NCOQ**

Sound data $\Delta p = 125$ Pa

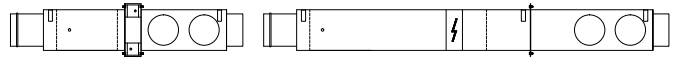

Model	data referring to inlet spigot					$\Delta p = 125$ Pa																	
	Velocity		air volume			min. ΔP	discharge sound									radiated sound							
							L_w in dB/Oct. (re 1pW)						Lp values			L_w in dB/Oct. (re 1pW)						Lp values	
	m/s	l/s	CFM	m ³ /h	Pa	125 Hz	250 Hz	500 Hz	1000	2000	4000	dB (A)	NC	NR	125 Hz	250 Hz	500 Hz	1000	2000	4000	dB (A)	NC	NR
					dB									DB									
100	2	15	31	53	3	32	30	20	-	-	-	--	--	--	-	-	-	-	-	-	--	--	--
	4	29	62	106	11	38	36	26	21	-	-	--	--	--	22	-	-	-	-	-	--	--	--
	6	44	94	160	24	42	40	30	25	20	-	--	--	--	26	20	-	-	-	18	--	--	--
	8	59	125	213	43	45	43	33	28	23	-	--	--	--	29	23	19	19	19	21	--	--	--
	10	74	156	266	67	47	46	36	32	27	-	20	--	--	32	26	22	21	21	23	--	--	--
125	2	23	49	84	3	29	28	20	-	-	-	--	--	--	-	-	-	-	-	-	--	--	--
	4	47	99	168	10	36	35	26	22	-	-	--	--	--	23	18	-	-	-	-	--	--	--
	6	70	149	253	23	40	39	30	26	19	-	--	--	--	27	22	19	18	-	19	--	--	--
	8	94	198	337	40	44	43	34	30	23	-	--	--	--	30	25	22	21	20	22	--	--	--
	10	117	248	421	63	47	46	37	33	26	-	20	--	--	33	28	25	23	22	24	--	--	--
160	2	39	82	139	2	28	27	20	-	-	-	--	--	--	18	-	-	-	-	-	--	--	--
	4	78	164	279	9	35	33	25	22	-	-	--	--	--	25	20	19	-	-	-	--	--	--
	6	116	246	418	21	40	38	29	26	20	-	--	--	--	29	24	23	20	18	20	--	--	--
	8	155	328	558	38	44	41	33	29	23	-	--	--	--	32	27	26	23	21	23	--	--	--
	10	194	410	697	59	47	44	36	32	25	18	--	--	--	34	29	28	25	23	25	--	--	--
200	2	61	129	219	2	28	20	-	-	-	-	--	--	--	19	-	-	-	-	-	--	--	--
	4	122	258	439	9	37	30	26	20	-	-	--	--	--	26	22	21	18	-	-	--	--	--
	6	183	387	658	21	42	36	31	24	17	-	--	--	--	30	26	25	22	20	21	--	--	--
	8	244	516	878	38	46	40	35	28	21	-	--	--	--	33	29	28	25	22	24	--	--	--
	10	305	645	1097	59	49	44	38	30	24	-	20	--	--	35	31	30	27	25	26	--	--	--
250	2	96	203	345	2	30	29	21	-	-	-	--	--	--	19	-	-	-	-	-	--	--	--
	4	192	406	690	9	38	36	29	23	-	-	--	--	--	26	21	21	18	-	-	--	--	--
	6	288	609	1035	21	44	41	34	27	19	-	--	--	--	30	25	25	22	20	21	--	--	--
	8	383	812	1380	38	47	45	37	30	22	-	--	--	--	33	28	28	25	23	24	--	--	--
	10	479	1015	1725	59	51	48	40	32	25	18	22	--	--	35	31	31	27	25	26	--	--	--
315	2	153	324	550	2	34	35	21	19	-	-	--	--	--	21	18	18	-	-	-	--	--	--
	4	306	648	1101	9	43	41	28	24	19	-	--	--	--	28	25	25	22	18	19	--	--	--
	6	459	971	1651	21	49	46	33	29	23	-	21	--	--	32	29	29	26	22	23	--	--	--
	8	612	1295	2202	38	54	50	37	33	27	19	25	--	20	35	32	32	29	25	26	--	--	--
	10	764	1619	2752	59	58	53	40	36	30	22	29	22	24	38	34	34	31	27	28	--	--	--
355	2	195	412	701	2	34	42	25	23	-	-	--	--	--	22	19	19	-	-	-	--	--	--
	4	389	824	1401	9	44	46	31	27	19	-	--	--	--	29	26	26	23	18	20	--	--	--
	6	584	1236	2102	21	50	49	35	31	22	18	23	--	--	33	30	30	27	23	24	--	--	--
	8	779	1649	2803	38	55	52	39	34	25	21	27	--	22	36	33	33	30	25	27	--	--	--
	10	973	2061	3503	59	59	55	42	37	28	24	30	23	25	38	35	35	32	28	29	--	--	--
400	2	248	524	891	2	35	44	26	24	17	-	--	--	--	22	19	19	-	-	-	--	--	--
	4	495	1049	1783	9	45	48	32	28	21	-	20	--	--	29	26	26	24	19	20	--	--	--
	6	743	1573	2674	21	51	51	36	32	24	-	24	--	21	33	30	30	28	23	24	--	--	--
	8	990	2097	3565	38	56	54	40	35	27	19	28	21	24	36	33	33	31	26	27	--	--	--
	10	1238	2621	4456	59	60	57	43	38	30	22	32	25	27	39	36	36	33	28	29	--	--	--

1. Sound data is determined in a reverberation room at an independent sound laboratory, according to ISO3741 and ISO 5135 standards.
2. L_w in dB/Oct. (re 1pW) are sound power levels for discharge sound and case radiated sound. Figures less than 17 dB are indicated by "--".
3. The discharge sound pressure levels are determined with the assumptions as mentioned in table 1 for downstream ductwork including a diffuser with insulated plenum box.
4. The radiated sound pressure levels are determined with the assumptions as mentioned in table 1 for ceiling plenum and suspended ceiling absorption.

5. Lp values are including a room absorption of 10 dB/Oct.
6. dB(A), NC and NR index figures are sound pressure levels. Figures less than 20 are indicated by "--".
7. \square p is total pressure drop across VAV air volume control terminal with damper fully open.
8. For insertion loss see table 2.
9. For non standard applications and/or selections, please contact our technical staff.

Table 1: Assumptions for additional attenuation

Hz	125	250	500	1K	2K	4K
Discharge (dB)	5	10	20	30	30	25
Radiated (dB)	2	5	10	15	15	20

Table 2: Insertion Loss

Model	125	250	500	1K	2K	4K	Hz
100	13	17	23	26	28	30	dB
125	12	15	22	25	27	29	dB
160	12	15	22	25	27	29	dB
200	11	15	21	24	26	28	dB
250	11	15	21	24	26	28	dB
315	8	11	21	24	26	26	dB
355	8	11	21	24	26	26	dB
400	8	11	21	24	26	26	dB

Compact VAV and CAV air volume control terminals

Type **NCOJ** **NCOQ**

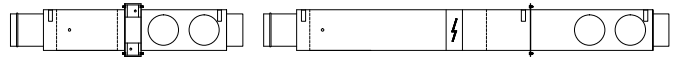

Sound data $\Delta p = 250$ Pa

Model	data referring to inlet spigot				min. ΔP	$\Delta p = 250$ Pa																													
						discharge sound						radiated sound																							
	Velocity		air volume			L_w in dB/Oct. (re 1pW)						Lp values			L_w in dB/Oct. (re 1pW)						Lp values														
						125 Hz	250 Hz	500 Hz	1000	2000	4000	dB (A)	NC	NR	125 Hz	250 Hz	500 Hz	1000	2000	4000	dB (A)	NC	NR												
m/s	l/s	CFM	m ³ /h	Pa	dB						dB																								
100	2	15	31	53	3	34	34	26	21	-	-	-	-	21	-	-	-	-	-	-	-	-	-	-	-	-	-	-	-	-	-	-	-	-	-
	4	29	62	106	11	40	39	31	26	21	-	-	-	28	22	18	-	-	18	-	-	-	-	-	-	-	-	-	-	-	-	-	-	-	
	6	44	94	160	24	44	43	34	29	25	-	-	-	32	26	22	20	20	22	-	-	-	-	-	-	-	-	-	-	-	-	-	-	-	
	8	59	125	213	43	46	46	37	32	28	-	-	-	35	29	25	23	23	25	-	-	-	-	-	-	-	-	-	-	-	-	-	-	-	-
	10	74	156	266	67	48	48	39	34	31	20	22	-	38	32	28	25	25	27	-	-	-	-	-	-	-	-	-	-	-	-	-	-	-	
125	2	23	49	84	3	32	33	26	22	-	-	-	-	22	17	-	-	-	-	-	-	-	-	-	-	-	-	-	-	-	-	-	-	-	
	4	47	99	168	10	39	39	31	27	21	-	-	-	29	24	21	18	-	19	-	-	-	-	-	-	-	-	-	-	-	-	-	-	-	
	6	70	149	253	23	43	43	35	30	24	-	-	-	33	28	25	22	21	23	-	-	-	-	-	-	-	-	-	-	-	-	-	-	-	
	8	94	198	337	40	46	46	38	33	27	18	-	-	36	31	28	25	24	26	-	-	-	-	-	-	-	-	-	-	-	-	-	-	-	
	10	117	248	421	63	49	48	40	35	29	21	22	-	39	34	31	27	26	28	-	-	-	-	-	-	-	-	-	-	-	-	-	-	-	-
160	2	39	82	139	2	32	33	26	22	20	-	-	-	24	19	18	-	-	-	-	-	-	-	-	-	-	-	-	-	-	-	-	-	-	
	4	78	164	279	9	39	39	32	28	23	17	-	-	31	26	25	20	18	20	-	-	-	-	-	-	-	-	-	-	-	-	-	-	-	
	6	116	246	418	21	44	42	35	31	26	19	-	-	35	30	29	24	22	24	-	-	-	-	-	-	-	-	-	-	-	-	-	-	-	
	8	155	328	558	38	47	45	38	34	28	21	20	-	38	33	32	27	25	27	-	-	-	-	-	-	-	-	-	-	-	-	-	-	-	
	10	194	410	697	59	50	48	40	36	30	23	22	-	40	35	34	29	27	29	-	-	-	-	-	-	-	-	-	-	-	-	-	-	-	
200	2	61	129	219	2	33	25	21	17	-	-	-	-	25	21	20	-	-	-	-	-	-	-	-	-	-	-	-	-	-	-	-	-	-	
	4	122	258	439	9	41	34	30	25	19	-	-	-	32	28	27	22	19	21	-	-	-	-	-	-	-	-	-	-	-	-	-	-	-	
	6	183	387	658	21	46	40	35	29	23	-	-	-	36	32	31	26	23	25	-	-	-	-	-	-	-	-	-	-	-	-	-	-	-	
	8	244	516	878	38	49	44	39	32	26	18	20	-	39	35	34	29	26	28	-	-	-	-	-	-	-	-	-	-	-	-	-	-	-	
	10	305	645	1097	59	52	47	42	34	29	21	23	-	41	37	36	31	29	30	-	-	-	-	-	-	-	-	-	-	-	-	-	-	-	
250	2	96	203	345	2	34	34	26	22	-	-	-	-	25	20	20	-	-	-	-	-	-	-	-	-	-	-	-	-	-	-	-	-	-	
	4	192	406	690	9	42	41	34	28	22	-	-	-	32	27	27	22	20	21	-	-	-	-	-	-	-	-	-	-	-	-	-	-	-	
	6	288	609	1035	21	47	46	38	32	25	19	20	-	36	31	31	26	24	25	-	-	-	-	-	-	-	-	-	-	-	-	-	-	-	
	8	383	812	1380	38	51	49	41	35	28	22	23	-	39	34	34	29	27	28	-	-	-	-	-	-	-	-	-	-	-	-	-	-	-	
	10	479	1015	1725	59	54	52	44	37	30	24	26	-	41	37	37	31	29	30	-	-	-	-	-	-	-	-	-	-	-	-	-	-	-	
315	2	153	324	550	2	37	40	26	25	21	-	-	-	27	24	24	19	-	-	-	-	-	-	-	-	-	-	-	-	-	-	-	-	-	
	4	306	648	1101	9	46	46	32	30	25	18	20	-	34	31	31	26	22	23	-	-	-	-	-	-	-	-	-	-	-	-	-	-	-	
	6	459	971	1651	21	52	50	37	33	28	21	24	-	38	35	35	30	26	27	-	-	-	-	-	-	-	-	-	-	-	-	-	-	-	
	8	612	1295	2202	38	56	53	40	36	31	24	28	20	41	38	38	33	29	30	-	-	-	-	-	-	-	-	-	-	-	-	-	-	-	
	10	764	1619	2752	59	60	56	43	39	34	27	31	24	44	40	40	35	31	32	22	-	-	-	-	-	-	-	-	-	-	-	-	-	-	
355	2	195	412	701	2	37	47	30	29	23	21	-	-	28	25	25	20	-	-	-	-	-	-	-	-	-	-	-	-	-	-	-	-	-	
	4	389	824	1401	9	47	51	36	33	26	23	23	-	35	32	32	27	22	24	-	-	-	-	-	-	-	-	-	-	-	-	-	-	-	
	6	584	1236	2102	21	53	53	40	36	28	25	27	20	39	36	36	31	26	28	-	-	-	-	-	-	-	-	-	-	-	-	-	-	-	
	8	779	1649	2803	38	57	56	43	38	30	27	30	23	42	39	39	34	29	31	20	-	-	-	-	-	-	-	-	-	-	-	-	-	-	
	10	973	2061	3503	59	61	58	45	41	32	29	33	26	44	41	41	36	32	33	23	-	-	-	-	-	-	-	-	-	-	-	-	-	-	
400	2	248	524	891	2	38	49	31	30	25	19	21	-	28	25	25	21	-	17	-	-	-	-	-	-	-	-	-	-	-	-	-	-		
	4	495	1049	1783	9	48	53	37	34	28	21	25	-	35	32	32	28	23	24	-	-	-	-	-	-	-	-	-	-	-	-	-	-	-	
	6	743	1573	2674	21	54	55	41	37	30	23	28	-	39	36	36	32	27	28	-	-	-	-	-	-	-	-	-	-	-	-	-	-	-	
	8	990	2097	3565	38	58	58	44	39	32	25	31	21	42	39	39	35	30	31	21	-	-	-	-	-	-	-	-	-	-	-	-	-	-	
	10	1238	2621	4456	59	62	60	46	42	34	27	34	25	45	42	42	37	32	33	23	-	-	-	-	-	-	-	-	-	-	-	-	-	-	

1. Sound data is determined in a reverberation room at an independent sound laboratory, according to ISO3741 and ISO 5135 standards.
2. L_w in dB/Oct. (re 1pW) are sound power levels for discharge sound and case radiated sound. Figures less than 17 dB are indicated by "-".
3. The discharge sound pressure levels are determined with the assumptions as mentioned in table 1 for downstream ductwork including a diffuser with insulated plenum box.
4. The radiated sound pressure levels are determined with the assumptions as mentioned in table 1 for ceiling plenum and suspended ceiling absorption.

5. Lp values are including a room absorption of 10 dB/Oct.
6. dB(A), NC and NR index figures are sound pressure levels. Figures less than 20 are indicated by "-".
7. Δp is total pressure drop across VAV air volume control terminal with damper fully open.
8. For insertion loss see table 2.
9. For non standard applications and/or selections, please contact our technical staff.

Table 1: Assumptions for additional attenuation

Hz	125	250	500	1K	2K	4K
Discharge (dB)	5	10	20	30	30	25
Radiated (dB)	2	5	10	15	15	20

Table 2: Insertion Loss

Model	125	250	500	1K	2K	4K	Hz
100	13	17	23	26	28	30	dB
125	12	15	22	25	27	29	dB
160	12	15	22	25	27	29	dB
200	11	15	21	24	26	28	dB
250	11	15	21	24	26	28	dB
315	8	11	21	24	26	26	dB
355	8	11	21	24	26	26	dB
400	8	11	21	24	26	26	dB

