

NR series

**Circular CAV air volume control terminals
with system powered mechanical regulator**

BARCOL-AIR

Circular CAV air volume control terminals with system powered mechanical regulator

Table of contents

Description	Page
Type designation	1
Technical data	
- General	2
- Specification	3
- Installation instruction	3
Model overview / dimensions	4 - 5
Sound data NROBOVO...	6 - 7
Sound data NBOCOVO...	8 - 9
Sound data NROG.VO.../NRON.VO...	10 - 11
Sound data NROJ.VO.../NROQ.VO...	12 - 13

Circular CAV air volume control terminals with system powered mechanical regulator

Type designation
NR.....

Composition type designation:

N - **R** - **O** - **B** - **O** - **O**

N Position 1: Product group

O = not applicable

Ordering example:

N	R	O	B	O	O	0	2	0	0	Q	9	0	5
See above						Model				Air volume (m ³ /h)			

R Position 2: Function

O = not applicable

R = circular CAV terminals with system powered mechanical regulator

1 = non standard, specify separately

O Position 3: Control

O = system powered, regulator (standard)

1 = non standard, specify separately regulator (standard)

B Position 4: Outlet

O = not applicable

B = circular outlet

C = 4 circular outlets ('Octopus')

G = rectangular outlet and provision for integral hot water reheat coil

J = 4 circular outlets and provision for integral hot water reheat coil

N = rectangular outlet and provision for integral electric reheat coil

Q = 4 circular outlets and provision for integral electric reheat coil

1 = non standard, specify separately

O Position 5: Reheat coil

O = without reheat coil

A = 1-row hot water reheat

B = 2-row hot water reheat

D = 4-row hot water reheat

E = 1-stage 230VAC/1-phase electric reheat coil

F = 2-stage 230VAC/1-phase electric reheat coil

G = 3-stage 230VAC/1-phase electric reheat coil

H = 1-stage 400VAC/3-phase electric reheat coil

J = 2-stage 400VAC/3-phase electric reheat coil

1 = non standard, specify separately

O Position 6: Finish

O = standard finish (galvanised steel)

P = powder paint coating

S = SUS304 + Aluminum painting

1 = non standard, specify separately

Ordering codes "Specials"

N..1... - 3004 = 'Octopus' with 4 outlets

N..1... - 3006 = 'Octopus' with 6 outlets

N..1... - 3016 = 'Octopus' with 6 outlets
and balancing dampers

N..1... - FL = Flange connection 30
mm for rectangular outlet

Ordering information:

Standard terminals:

- quantity of terminals
- complete 6 digit code
- terminal size or model
- air volume setting (V_{max} , V_{min} etc)
- control handing (standard right side)
- if applicable, electric reheat coil capacity
- supply or return air

Non standard terminals:

- for non standard terminals a full description and / or drawing are requested.

Circular CAV air volume control terminals with system powered mechanical regulator

Technical data
Type (NR.....)



Application

NR series circular, constant volume terminals with system powered mechanical regulator are designed to keep a constant air flow, independent of the inlet static pressure without the use of a DDC CAV/VAV controller/actuator. These terminals save commissioning time on site and are suitable either for supply or return air in new or refurbishment projects.

Features:

- Pressure independent from 50 - 1000 Pa.
- Compact design.
- Low pressure loss over the terminal.
- Control accuracy $\pm 10\%$.
- Temperature insensitive (-15°C to +100°C).
- Can be mounted in any orientation.
- Factory setting of airflow rate.
- Provision for on-site adjustment of airflow setting
- Maintenance free.
- Factory fitted optional distribution plenum with built-in hot water or electric reheat coil.
- Low noise.

Technical information

Casing:

Terminal casing made of galvanized sheet steel (non spiral) with sleeve connection and rubber gasket. Option for stainless steel body or power paint finish. Casing leakage class C according to EN1751 except model sizes NR 080, 100 and 125 which are class B.

Insulation:

The optional rectangular discharge section is internally insulated.

Damper:

Damper blade: aluminium.
Damper shaft: stainless steel with self lubricating nylon bearings.

Distribution plenum: (option)

Made of galvanised sheet steel with 13 mm internal isolation (30kg/m³). Plenum with standard rectangular or multiple (4 x circular) outlet construction. Optional single, double, triple or six circular outlets are possible. Outlet spigots are made of galvanised steel and can be provided with volume control dampers made of galvanised sheet steel.

Reheat coil:

Choice of 1.2 or 4-row hot water reheat coil or electric reheat coil (230VAC/1-phase or 400VAC/3-phase).

Controls:

- The factory setpoint is indicated on the terminal.

Delivery format:

- when ordering, the required air volume must be indicated.

Recommended air volume

Model Ø	m ³ /h		
	Min	-	Max
80	54	-	145
100	85	-	226
125	132	-	353
140	166	-	443
160	217	-	579
200	339	-	904
250	530	-	1413
315	841	-	2243
400	1356	-	3617

Circular CAV air volume control terminals with system powered mechanical regulator

Technical data
Type (NR.....)



Specify as:

Example:

Supply and install, circular, pressure independent constant air volume terminals with system powered mechanical regulator; control accuracy $\pm 10\%$ in the recommended flow range. The construction shall be galvanized sheet steel with a casing leakage rate classified as class C according to standard EN1751, except models NR 080, 100, 125 which are class B.

The CAV terminals shall have an aluminium damper blade with stainless steel shaft rotating in self lubricating nylon bearings.

Air volume 161 l/s
Terminal size 200mm
Max. pressure loss 60 Pa
Max. discharge sound index < NC35 (@250Pa)
Max. radiated sound index < NC28 (@250Pa)

Barcol-Air control type "V", factory set with provision for on-site adjustment of air flow setting. (Barcol-Air type NROBOVO).

Ordering example: type - model - airflow (m³/h) = NROBOVO - 0200 - Q580 (= 161 l/s)

Manufacturer: Barcol-Air

Installation Instructions:

The Barcol-Air CAV terminals shall be installed in, and supported by the circular connecting ducts. The circular ducts should be supported either side of the CAV by circular suspension brackets with anti-vibration rubber between the support brackets and the ducts to prevent vibration and to avoid a thermal bridge. (See picture below).

The installation method:

1. Shall prevent the body of the CAV terminal from high mechanical tension, which could damage the construction and performance of the terminal.

2. Shall prevent torsion on the CAV terminals, which could cause malfunction of the damper blades.
3. Provides some flexibility to the final location of the CAV terminals.
4. Use at least 1 x diameter straight duct length before the CAV inlet.
5. Additional manual volume control dampers (VCD)'s before the inlet are not required / recommended!!
6. All connections shall be thermally isolated.

See drawing below.

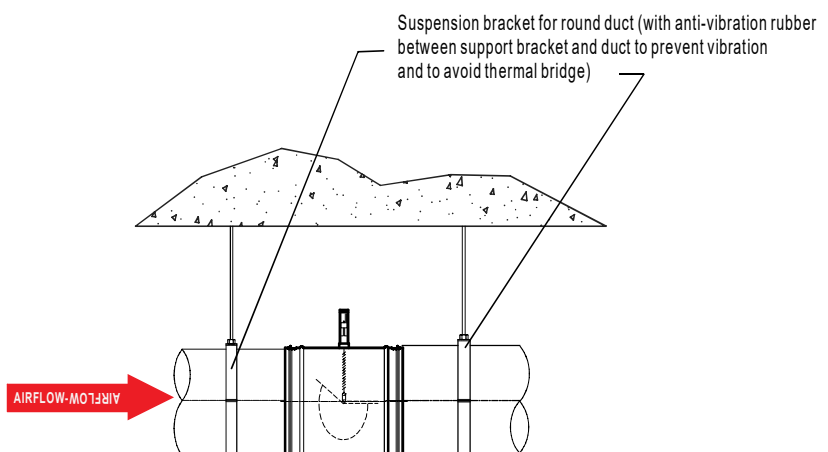

Circular CAV air volume control terminals with system powered mechanical regulator

Model overview
(NR.....)

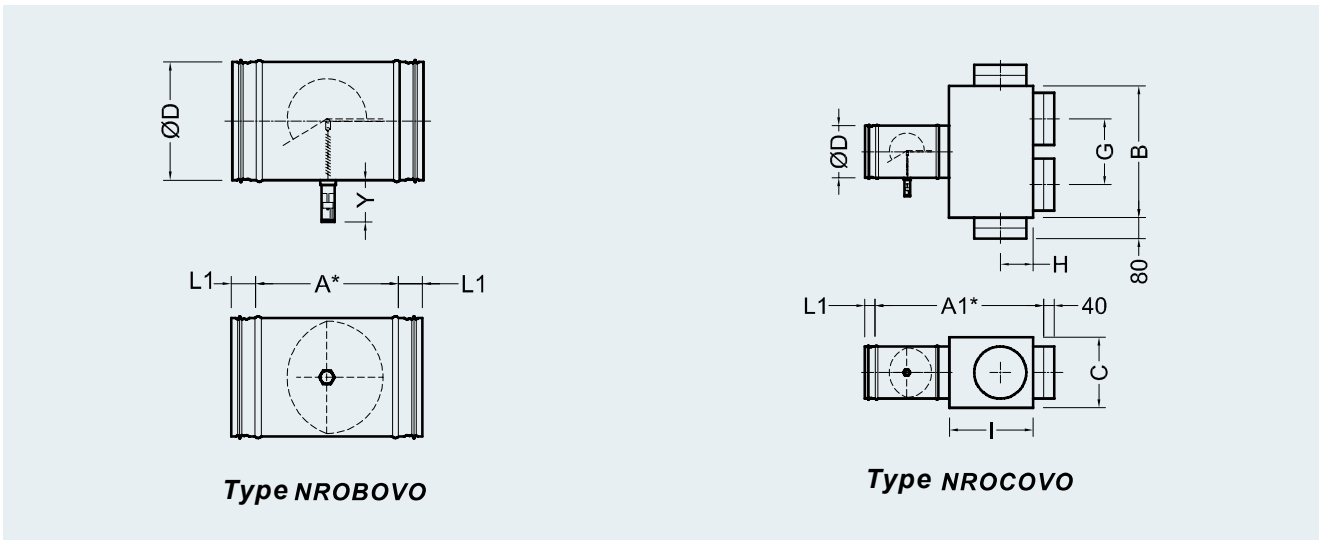

Dimensions NR

Model	80	100	125	140	160	200	250	315	400
A	170	170	170	170	240	240	240	260	335
A1	520	520	520	520	590	640	690	760	935
A2	970	970	970	970	1040	1090	1140	1210	1385
A3	710	710	710	710	780	780	780	800	875
B	330	330	330	360	400	500	600	740	910
B1	330	330	330	360	400	400	600	600	600
C	228	228	228	228	248	268	318	408	458
D	78	98	123	138	158	198	248	313	398
E	275	275	275	305	350	450	550	690	850
E1	275	275	275	305	350	350	550	550	550
F	170	170	170	170	175	200	250	330	380
G	180	180	180	195	215	255	305	370	455
H	125	125	125	125	125	125	175	200	250
I	270	270	270	270	270	320	370	420	520
I1	720	720	720	720	720	770	820	870	970
L1	40	40	40	40	40	40	40	40	40
Y	70	70	70	70	70	70	70	70	70

All dimensions in mm.
 * = Installed length.
 ** = Size varies with a 1- 2-row or 4-row hot water reheat coil.

Circular CAV air volume control terminals with system powered mechanical regulator

Model overview
(NR.....)

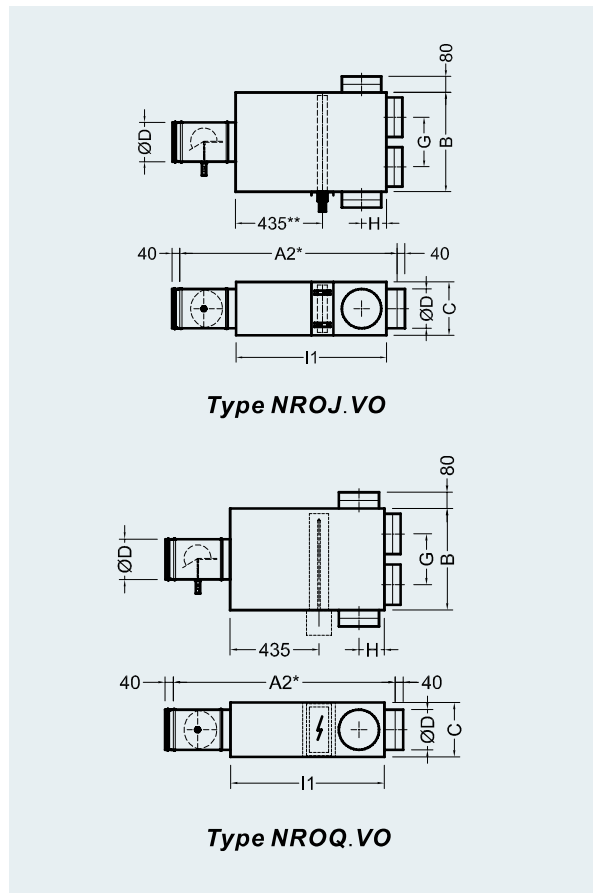
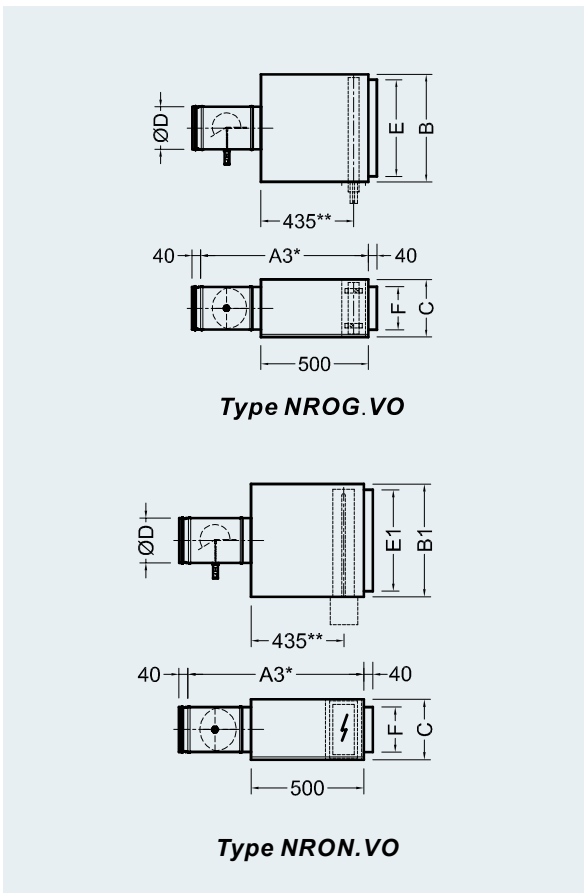
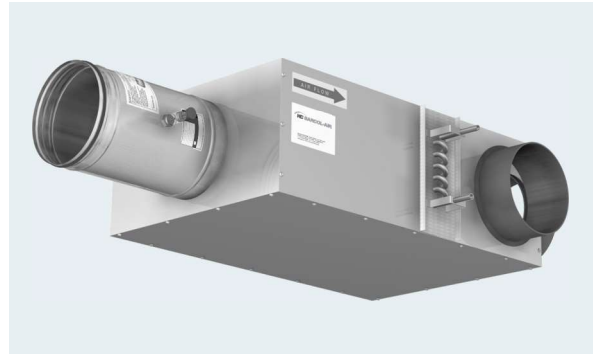

For dimensions see page 4

Circular CAV air volume control terminals with system powered mechanical regulator

Type NROBOVO

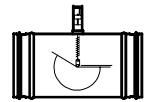

Sound data $\Delta p = 125 \text{ Pa}$

Model	Data referring to inlet spigot					$\Delta p = 125 \text{ Pa}$																	
	Velocity		Air volume			Min. Δp_s	Discharge sound						Radiated sound single wall										
							L_w in dB/Oct. (re 1pW)						Lp values			L_w in dB/Oct. (re 1pW)						Lp values	
	m/s	l/s	CFM	m ³ /h	Pa	125 Hz	250 Hz	500 Hz	1000	2000	4000	dB (A)	NC	NR	125 Hz	250 Hz	500 Hz	1000	2000	4000	dB (A)	NC	NR
dB						dB																	
80	2.4	11	24	40	41	40	37	36	35	36	30	--	--	--	20	-	-	18	-	--	--	--	
	4.0	19	39	67	47	48	44	42	40	40	33	--	--	--	28	20	18	21	22	-	--	--	--
	6.0	28	59	100	69	52	48	46	44	44	38	24	--	--	32	24	22	26	26	21	--	--	--
	7.5	35	74	125	98	54	50	48	47	47	41	26	--	20	34	26	25	28	29	24	--	--	--
100	2.6	19	41	70	41	44	41	38	37	35	30	--	--	--	26	17	-	19	18	-	--	--	--
	4.0	29	62	106	47	49	45	43	42	40	35	20	--	--	30	22	20	24	23	18	--	--	--
	6.0	44	94	160	70	53	49	47	46	45	40	25	--	--	34	26	24	29	28	23	--	--	--
	8.3	61	129	220	100	55	52	49	49	48	43	27	--	21	36	28	26	31	30	26	--	--	--
125	2.4	28	59	100	41	44	42	39	38	38	32	--	--	--	24	21	20	22	23	19	--	--	--
	4.0	47	99	168	47	51	47	44	42	41	35	23	--	--	31	26	25	26	26	22	--	--	--
	6.0	70	149	253	70	55	52	48	46	46	40	27	--	21	35	31	29	30	31	27	--	--	--
	6.7	78	165	280	81	56	53	49	47	47	41	28	--	22	36	32	30	31	32	28	--	--	--
140	2.8	42	82	150	42	48	44	41	38	37	32	--	--	--	30	27	28	27	25	19	--	--	--
	4.0	58	124	210	47	51	48	45	42	42	36	23	--	--	33	30	32	31	29	23	--	--	--
	6.0	89	188	320	70	56	52	50	47	47	41	27	--	22	38	35	36	36	34	28	--	--	--
	7.5	111	235	400	100	58	55	52	49	49	44	30	22	24	40	37	39	38	37	31	21	--	--
160	2.6	50	106	180	41	46	44	40	37	37	30	--	--	--	29	29	28	27	26	19	--	--	--
	4.0	78	164	279	47	51	49	45	43	42	35	23	--	--	34	34	33	33	31	24	--	--	--
	6.0	116	246	418	70	55	53	49	47	47	40	28	--	23	38	38	38	37	36	29	20	--	--
	7.2	139	294	500	92	57	55	51	49	49	43	29	22	25	40	40	40	39	38	32	22	--	--
200	2.3	69	147	250	41	46	43	41	41	40	34	--	--	--	29	30	30	32	29	24	--	--	--
	4.0	122	258	439	47	52	49	46	44	43	37	24	--	--	35	36	35	35	32	27	--	--	--
	6.0	183	387	658	70	56	53	50	49	48	42	28	21	23	39	40	39	40	37	32	22	--	--
	8.2	250	529	900	117	60	56	54	53	52	46	32	24	26	43	43	43	44	41	36	25	--	--
250	2.9	139	294	500	42	50	47	44	41	40	33	22	--	--	31	34	33	27	30	23	--	--	--
	4.0	192	406	690	47	53	51	48	45	44	37	26	--	20	35	38	37	31	34	27	--	--	--
	6.0	288	609	1035	70	58	55	52	50	49	42	30	22	25	39	42	42	36	39	32	23	--	--
	8.7	417	882	1500	132	X	X	X	X	X	X	X	X	X	X	X	X	X	X	X	X	X	X
315	2.9	222	471	800	41	51	48	44	41	40	33	23	--	--	34	32	29	29	28	24	--	--	--
	4.0	306	648	1101	47	55	52	48	45	44	37	26	--	21	37	36	33	33	32	28	--	--	--
	6.0	459	971	1651	70	59	56	52	50	49	43	31	23	26	41	40	38	37	37	33	21	--	--
	10.2	778	1647	2800	184	X	X	X	X	X	X	X	X	X	X	X	X	X	X	X	X	X	X
400	2.2	278	588	1000	43	50	47	45	44	43	36	22	--	--	35	32	31	32	33	24	--	--	--
	4.0	495	1049	1783	47	56	52	48	47	46	39	27	--	21	41	37	34	35	36	30	--	--	--
	6.0	743	1573	2674	70	60	56	53	52	51	44	32	25	27	45	42	39	40	41	35	24	--	--
	9.0	1111	2353	4000	141	X	X	X	X	X	X	X	X	X	X	X	X	X	X	X	X	X	X

1. Sound data is determined in a reverberation room at an independent sound laboratory, according to ISO3741 and ISO 5135 standards.
2. L_w in dB/Oct. (re 1pW) are sound power levels for discharge sound and case radiated sound. Figures less than 17 dB are indicated by "--".
3. The discharge sound pressure levels are determined with the assumptions as mentioned in table 1 for downstream ductwork including a diffuser with insulated plenum box.
4. The radiated sound pressure levels are determined

- with the assumptions as mentioned in table 1 for ceiling plenum and suspended ceiling absorption.
5. Lp values are including a room absorption of 10 dB/Oct.
6. DB(A), NC and NR index figures are sound pressure levels. Figures less than 20 are indicated by "--".
7. Δp_s is static pressure drop across VAV air volume control terminal with damper fully open.
8. For non standard applications and/or selections, please contact our technical staff.

Table 1 : Assumptions for additional attenuation

Hz	125	250	500	1K	2K	4K
Discharge (dB)	5	10	20	30	30	25
Radiated (dB)	2	5	10	15	15	20

Circular CAV air volume control terminals with system powered mechanical regulator

Type NROBOVO

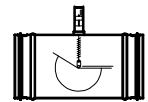

Sound data $\Delta p = 250 \text{ Pa}$

Model	Data referring to inlet spigot					$\Delta p = 250 \text{ Pa}$																		
						Discharge sound						Radiated sound single wall												
	Velocity		Air volume			Min. Δp_s	L_w in dB/Oct. (re 1pW)						Lp values			L_w in dB/Oct. (re 1pW)						Lp values		
							125 Hz	250 Hz	500 Hz	1000	2000	4000	dB (A)	NC	NR	125 Hz	250 Hz	500 Hz	1000	2000	4000	dB (A)	NC	NR
m/s	L/s	CFM	m ³ /h	Pa	dB						dB													
80	2.4	11	24	40	41	47	44	43	42	43	37	--	--	--	26	20	19	23	25	20	--	--	--	
	4.0	19	39	67	47	55	51	48	46	46	40	26	--	21	34	27	25	28	28	23	--	--	--	
	6.0	28	59	100	69	59	55	52	51	51	45	30	23	25	38	31	29	32	33	28	--	--	--	
	7.5	35	74	125	98	61	57	55	53	53	47	33	26	28	41	33	31	35	35	30	--	--	--	
100	2.6	19	41	70	41	48	47	45	45	45	40	21	--	--	30	23	22	28	27	23	--	--	--	
	4.0	29	62	106	47	55	52	49	48	47	41	27	--	21	37	28	26	31	30	25	--	--	--	
	6.0	44	94	160	70	59	56	54	53	52	46	31	24	26	41	33	31	35	34	30	--	--	--	
	8.3	61	129	200	100	61	58	56	55	54	49	34	27	28	43	35	33	38	37	33	--	--	--	
125	2.4	28	59	100	41	50	48	45	44	45	39	23	--	--	31	27	26	28	29	26	--	--	--	
	4.0	47	99	168	47	57	54	50	48	48	41	29	22	24	38	33	31	32	32	28	--	--	--	
	6.0	70	149	253	70	62	58	55	53	53	46	33	27	29	42	37	36	37	37	33	20	--	--	
	6.7	78	165	280	81	63	59	56	54	54	47	34	28	32	43	38	37	38	38	34	21	--	--	
140	2.8	42	88	150	42	53	50	49	47	47	42	25	--	--	35	33	35	36	35	29	--	--	--	
	4.0	58	124	210	47	58	54	52	49	48	42	30	22	24	40	37	38	38	36	29	20	--	--	
	6.0	89	188	320	70	62	59	56	53	53	48	34	28	29	44	41	43	42	41	35	25	--	--	
	7.5	111	235	400	100	64	61	59	56	56	50	36	30	32	46	44	45	45	43	37	27	--	21	
160	2.6	50	106	180	41	52	51	48	47	47	41	25	--	--	34	36	36	37	36	30	--	--	--	
	4.0	78	164	279	47	58	55	51	49	49	42	30	22	25	40	41	40	39	38	31	22	--	--	
	6.0	116	246	418	70	62	60	56	54	54	47	34	27	30	44	45	44	44	43	36	27	--	21	
	7.2	139	294	500	92	64	61	58	56	56	49	36	30	32	46	47	46	46	45	38	29	20	23	
200	2.3	69	147	250	41	52	50	48	47	46	41	25	--	--	35	37	37	38	36	30	--	--	--	
	4.0	122	258	439	47	59	55	52	51	50	44	31	23	25	42	42	41	42	39	33	24	--	--	
	6.0	183	387	658	70	63	60	57	56	54	49	35	29	30	46	47	46	47	44	38	28	--	22	
	8.2	250	529	900	117	66	63	60	59	58	53	38	33	34	49	50	49	50	48	42	32	23	26	
250	2.9	139	294	500	42	56	54	52	51	50	44	29	21	24	37	41	42	36	40	34	23	--	--	
	4.0	192	406	690	47	60	57	54	52	50	43	32	25	27	41	44	44	37	40	33	25	--	--	
	6.0	288	609	1035	70	64	62	59	57	55	48	37	30	32	46	49	48	42	45	38	30	22	24	
	8.7	417	882	1500	132	68	66	63	61	60	53	40	35	36	50	53	53	47	50	43	34	26	28	
315	2.9	222	471	800	41	57	56	53	51	51	44	30	23	26	40	40	38	39	38	35	22	--	--	
	4.0	306	648	1101	47	61	58	54	52	51	44	33	26	28	44	42	40	39	39	34	23	--	--	
	6.0	459	971	1651	70	65	63	59	57	56	49	38	32	33	48	47	44	44	44	40	28	--	22	
	10.2	778	1647	2800	184	71	64	60	63	62	56	43	39	39	53	53	50	50	50	46	34	26	28	
400	2.2	278	588	1000	43	57	54	51	50	50	43	29	21	23	42	39	37	38	39	34	21	--	--	
	4.0	495	1049	1783	47	62	58	55	54	53	46	34	28	29	47	44	41	42	42	37	26	--	20	
	6.0	743	1573	2674	70	67	63	60	58	58	51	38	33	34	52	48	46	46	47	42	30	23	25	
	9.0	1111	2353	4000	141	71	67	64	63	63	56	43	39	39	56	53	50	51	52	47	35	28	30	

- Sound data is determined in a reverberation room at an independent sound laboratory, according to ISO3741 and ISO 5135 standards.
- L_w in dB/Oct. (re 1pW) are sound power levels for discharge sound and case radiated sound. Figures less than 17 dB are indicated by "--".
- The discharge sound pressure levels are determined with the assumptions as mentioned in table 1 for downstream ductwork including a diffuser with insulated plenum box.
- The radiated sound pressure levels are determined

- with the assumptions as mentioned in table 1 for ceiling plenum and suspended ceiling absorption.
- Lp values are including a room absorption of 10 dB/Oct.
- DB(A), NC and NR index figures are sound pressure levels. Figures less than 20 are indicated by "--".
- Δp_s is static pressure drop across VAV air volume control terminal with damper fully open.
- For non standard applications and/or selections, please contact our technical staff.

Table 1 : Assumptions for additional attenuation

Hz	125	250	500	1K	2K	4K
Discharge (dB)	5	10	20	30	30	25
Radiated (dB)	2	5	10	15	15	20

Circular CAV air volume control terminals with system powered mechanical regulator

Type NROCOVO

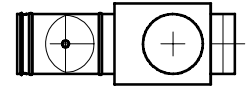

Sound data $\Delta p = 125 \text{ Pa}$

Model	Data referring to inlet spigot				Min. Δp_s	$\Delta p = 125 \text{ Pa}$																	
						Discharge sound						Radiated sound single wall											
	Velocity		Air volume			L_w in dB/Oct. (re 1pW)						Lp values			L_w in dB/Oct. (re 1pW)						Lp values		
						125 Hz	250 Hz	500 Hz	1000 Hz	2000 Hz	4000 Hz	dB (A)	NC	NR	125 Hz	250 Hz	500 Hz	1000	2000	4000	dB (A)	NC	NR
m/s	l/s	CFM	m ³ /h	Pa	dB									dB									
80	2.4	11	24	40	41	40	37	36	35	36	30	--	--	--	20	-	-	-	18	-	--	--	--
	4.0	19	39	67	47	48	44	42	40	40	33	--	--	--	28	20	18	21	22	-	--	--	--
	6.0	28	59	100	69	52	48	46	44	44	38	24	--	--	32	24	22	26	26	21	--	--	--
	7.5	35	74	125	98	54	50	48	47	47	41	26	--	20	34	26	25	28	29	24	--	--	--
100	2.6	19	41	70	41	44	41	38	37	35	30	--	--	--	26	17	-	19	18	-	--	--	--
	4.0	29	62	106	47	49	45	43	42	40	35	20	--	--	30	22	20	24	23	18	--	--	--
	6.0	44	94	160	70	53	49	47	46	45	40	25	--	--	34	26	24	29	28	23	--	--	--
	8.3	61	129	200	100	55	52	49	49	48	43	27	--	21	36	28	26	31	30	26	--	--	--
125	2.4	28	59	100	41	44	42	39	38	38	32	--	--	--	24	21	20	22	23	19	--	--	--
	4.0	47	99	168	47	51	47	44	42	41	35	23	--	--	31	26	25	26	26	22	--	--	--
	6.0	70	149	253	70	55	52	48	46	46	40	27	--	21	35	31	29	30	31	27	--	--	--
	6.7	78	165	280	81	56	53	49	47	47	41	28	--	22	36	32	30	31	32	28	--	--	--
140	2.8	42	88	150	42	48	44	41	38	37	32	--	--	--	30	27	28	27	25	18	--	--	--
	4.0	58	124	210	47	51	48	45	42	42	36	23	--	--	33	30	32	31	29	23	--	--	--
	6.0	89	188	320	70	56	52	50	47	47	41	27	--	22	38	35	36	36	34	28	--	--	--
	7.5	111	235	400	100	58	55	52	49	49	44	30	22	24	40	37	39	38	37	31	21	--	--
160	2.6	50	106	180	41	46	44	40	37	37	30	--	--	--	29	29	28	27	26	19	--	--	--
	4.0	78	164	279	47	51	49	45	43	42	35	23	--	--	34	34	33	33	31	24	--	--	--
	6.0	116	246	418	70	55	53	49	47	47	40	28	--	23	38	38	38	37	36	29	20	--	--
	7.2	139	294	500	92	57	55	51	49	49	43	29	22	25	40	40	40	39	38	32	22	--	--
200	2.3	69	147	250	41	46	43	41	41	40	34	--	--	--	29	30	30	32	29	24	--	--	--
	4.0	122	258	439	47	52	49	46	44	43	37	24	--	--	35	36	35	35	32	27	--	--	--
	6.0	183	387	658	70	56	53	50	49	48	42	28	21	23	39	40	39	40	37	32	22	--	--
	8.2	250	529	900	117	60	56	54	53	52	46	32	24	26	43	43	43	44	41	36	25	--	--
250	2.9	139	294	500	42	50	47	44	41	40	33	22	--	--	31	34	33	27	30	23	--	--	--
	4.0	192	406	690	47	53	51	48	45	44	37	26	--	20	35	38	37	31	34	27	--	--	--
	6.0	288	609	1035	70	58	55	52	50	49	42	30	22	25	39	42	42	36	39	32	23	--	--
	8.7	417	882	1500	132	X	X	X	X	X	X	X	X	X	X	X	X	X	X	X	X	X	X
315	2.9	222	471	800	41	51	48	44	41	40	33	23	--	--	34	32	29	29	28	24	--	--	--
	4.0	306	648	1101	47	55	52	48	45	44	37	26	--	21	37	36	33	33	32	28	--	--	--
	6.0	459	971	1651	70	59	56	52	50	49	43	31	23	26	41	40	38	37	37	33	21	--	--
	10.2	778	1647	2800	184	X	X	X	X	X	X	X	X	X	X	X	X	X	X	X	X	X	X
400	2.2	278	588	1000	43	50	47	45	44	43	36	22	--	--	35	32	31	32	33	27	--	--	--
	4.0	495	1049	1783	47	56	52	48	47	46	39	27	--	21	41	37	34	35	36	30	--	--	--
	6.0	743	1573	2674	70	60	56	53	52	51	44	32	25	27	45	42	39	40	41	35	24	--	--
	9.0	1111	2353	4000	141	X	X	X	X	X	X	X	X	X	X	X	X	X	X	X	X	X	X

1. Sound data is determined in a reverberation room at an independent sound laboratory, according to ISO3741 and ISO 5135 standards.
2. L_w in dB/Oct. (re 1pW) are sound power levels for discharge sound and case radiated sound. Figures less than 17 dB are indicated by "--".
3. The discharge sound pressure levels are determined with the assumptions as mentioned in table 1 for downstream ductwork including a diffuser with insulated plenum box.
4. The radiated sound pressure levels are determined with the assumptions as mentioned in table 1 for ceiling plenum and suspended ceiling absorption.

5. Lp values are including a room absorption of 10 dB/Oct.
6. DB(A), NC and NR index figures are sound pressure levels. Figures less than 20 are indicated by "--".
7. Δp_s is static pressure drop across VAV air volume control terminal with damper fully open.
8. For non standard applications and/or selections, please contact our technical staff.

Table 1: Assumptions for additional attenuation

Hz	125	250	500	1K	2K	4K
Discharge (dB)	5	10	20	30	30	25
Radiated (dB)	2	5	10	15	15	20

Table 2: Insertion Loss

Model	125	250	500	1K	2K	4K	Hz
80	9	10	11	13	15	15	dB
100	9	10	11	13	15	15	dB
125	8	9	10	12	14	14	dB
140	8	9	10	12	14	14	dB
160	8	9	10	12	14	14	dB
200	8	8	9	11	13	13	dB
250	7	8	9	11	13	13	dB
315	7	8	9	11	13	13	dB
400	7	8	9	11	13	13	dB

Circular CAV air volume control terminals with system powered mechanical regulator

Type NROCOVO

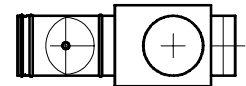

Sound data $\Delta p = 250$ Pa

Model	Data referring to inlet spigot				Min. Δp_s	$\Delta p = 250$ Pa																	
						Discharge sound						Radiated sound single wall											
	Velocity		Air volume			L_w in dB/Oct. (re 1pW)						Lp values			L_w in dB/Oct. (re 1pW)						Lp values		
						125 Hz	250 Hz	500 Hz	1000 Hz	2000 Hz	4000 Hz	dB (A)	NC	NR	125 Hz	250 Hz	500 Hz	1000	2000	4000	dB (A)	NC	NR
m/s	l/s	CFM	m ³ /h	Pa	dB									dB									
80	2.4	11	24	40	41	47	44	43	42	43	37	--	--	--	26	20	19	23	25	20	--	--	--
	4.0	19	39	67	47	55	51	48	46	46	40	26	--	21	34	27	25	28	28	23	--	--	--
	6.0	28	59	100	69	59	55	52	51	51	45	30	23	25	38	31	29	32	33	28	--	--	--
	7.5	35	74	125	98	61	57	55	53	53	47	33	26	28	41	33	31	35	35	30	--	--	--
100	2.6	19	41	70	41	48	47	45	45	45	40	21	--	--	30	23	22	28	27	23	--	--	--
	4.0	29	62	106	47	55	52	49	48	47	41	27	--	21	37	28	26	31	30	25	--	--	--
	6.0	44	94	160	70	59	56	54	53	52	46	31	24	26	41	33	31	35	34	30	--	--	--
	8.3	61	129	200	100	61	58	56	55	54	49	34	27	28	43	35	33	38	37	33	--	--	--
125	2.4	28	59	100	41	50	48	45	44	45	39	23	--	--	31	27	26	28	29	26	--	--	--
	4.0	47	99	168	47	57	54	50	48	48	41	29	22	24	38	33	31	32	32	28	--	--	--
	6.0	70	149	253	70	62	58	55	53	53	46	33	27	28	42	37	36	37	37	33	20	--	--
	6.7	78	165	280	81	63	59	56	54	54	47	34	28	29	43	38	37	38	38	34	21	--	--
140	2.8	42	88	150	42	53	50	49	47	47	42	25	--	--	35	33	35	36	35	29	--	--	--
	4.0	58	124	210	47	58	54	52	49	48	42	30	22	24	40	37	38	38	36	29	20	--	--
	6.0	89	188	320	70	62	59	56	53	53	48	34	28	29	44	41	43	42	41	35	25	--	--
	7.5	111	235	400	100	64	61	59	56	56	50	36	30	32	46	44	45	45	43	37	27	--	21
160	2.6	50	106	180	41	52	51	48	47	47	41	25	--	--	34	36	36	37	36	30	--	--	--
	4.0	78	164	279	47	58	55	51	49	49	42	30	22	25	40	41	40	39	38	31	22	--	--
	6.0	116	246	418	70	62	60	56	54	54	47	34	27	30	44	45	44	44	43	36	27	--	21
	7.2	139	294	500	92	64	61	58	56	56	49	36	30	32	46	47	46	46	45	38	29	20	23
200	2.3	69	147	250	41	52	50	48	47	46	41	25	--	--	35	37	37	38	36	30	--	--	--
	4.0	122	258	439	47	59	55	52	51	50	44	31	23	25	42	42	41	42	39	33	24	--	--
	6.0	183	387	658	70	63	60	57	56	54	49	35	29	30	46	47	46	47	44	38	28	--	22
	8.2	250	529	900	117	66	63	60	59	58	53	38	33	34	49	50	49	50	48	42	32	23	26
250	2.9	139	294	500	42	56	54	52	51	50	44	29	21	24	37	41	42	36	40	34	23	--	--
	4.0	192	406	690	47	60	57	54	52	50	43	32	25	27	41	44	44	37	40	33	25	--	--
	6.0	288	609	1035	70	64	62	59	57	55	48	37	30	32	46	49	48	42	45	38	30	22	24
	8.7	417	882	1500	132	68	66	63	61	60	53	40	35	36	50	53	53	47	50	43	34	26	28
315	2.9	222	471	800	41	57	53	53	51	51	44	30	23	26	40	40	38	39	38	35	22	--	--
	4.0	306	648	1101	47	61	58	54	52	51	44	33	26	28	44	42	40	39	39	34	23	--	--
	6.0	459	971	1651	70	65	63	59	57	56	49	38	32	33	48	47	44	44	44	40	28	--	22
	10.2	778	1647	2800	184	67	69	65	63	62	56	43	39	39	53	53	50	50	50	46	34	26	28
400	2.2	278	588	1000	43	57	54	51	50	50	43	29	21	23	42	39	37	38	39	34	21	--	--
	4.0	495	1049	1783	47	62	58	55	54	53	46	34	28	29	47	44	41	42	42	37	26	--	20
	6.0	743	1573	2674	70	67	63	60	58	58	51	38	33	34	52	48	46	46	47	42	30	23	25
	9.0	1111	2353	4000	141	71	67	64		63	56	43	39	39	56	53	50	51	52	47	35	28	30

1. Sound data is determined in a reverberation room at an independent sound laboratory, according to ISO3741 and ISO 5135 standards.
2. L_w in dB/Oct. (re 1pW) are sound power levels for discharge sound and case radiated sound. Figures less than 17 dB are indicated by "--".
3. The discharge sound pressure levels are determined with the assumptions as mentioned in table 1 for downstream ductwork including a diffuser with insulated plenum box.
4. The radiated sound pressure levels are determined with the assumptions as mentioned in table 1 for ceiling plenum and suspended ceiling absorption.

5. Lp values are including a room absorption of 10 dB/Oct.
6. DB(A), NC and NR index figures are sound pressure levels. Figures less than 20 are indicated by "--".
7. Δp_s is static pressure drop across VAV air volume control terminal with damper fully open.
8. For non standard applications and/or selections, please contact our technical staff.

Table 1: Assumptions for additional attenuation

Hz	125	250	500	1K	2K	4K
Discharge (dB)	5	10	20	30	30	25
Radiated (dB)	2	5	10	15	15	20

Table 2: Insertion Loss

Model	125	250	500	1K	2K	4K	Hz
80	9	10	11	13	15	15	dB
100	9	10	11	13	15	15	dB
125	8	9	10	12	14	14	dB
140	8	9	10	12	14	14	dB
160	8	9	10	12	14	14	dB
200	8	8	9	11	13	13	dB
250	7	8	9	11	13	13	dB
315	7	8	9	11	13	13	dB
400	7	8	9	11	13	13	dB

Circular CAV air volume control terminals with system powered mechanical regulator

Type NROG.VO
NRON.VO

Sound data $\Delta p = 125 \text{ Pa}$



Model	Data referring to inlet spigot				Min. Δp_s	$\Delta p = 125 \text{ Pa}$																	
	Velocity	Air volume				Discharge sound						Radiated sound single wall											
						L_w in dB/Oct. (re 1pW)						Lp values			L_w in dB/Oct. (re 1pW)						Lp values		
						125 Hz	250 Hz	500 Hz	1000 Hz	2000 Hz	4000 Hz	dB (A)	NC	NR	125 Hz	250 Hz	500 Hz	1000	2000	4000	dB (A)	NC	NR
m/s	l/s	CFM	m ³ /h	Pa	dB						dB												
80	2.4	11	24	40	42	35	30	24	23	24	-	--	--	--	20	-	-	-	18	-	--	--	--
	4.0	19	39	67	51	43	36	29	27	27	19	--	--	--	28	20	18	21	22	-	--	--	--
	6.0	28	59	100	77	46	40	33	31	31	23	--	--	--	32	24	22	26	26	21	--	--	--
	7.5	35	74	125	110	48	42	35	33	33	25	--	--	--	34	26	25	28	29	24	--	--	--
100	2.6	19	41	70	42	39	33	26	25	23	-	--	--	--	26	17	-	19	18	-	--	--	--
	4.0	29	62	106	50	43	38	30	29	28	20	--	--	--	30	22	20	24	23	18	--	--	--
	6.0	44	94	160	77	47	41	34	33	32	25	--	--	--	34	26	24	29	28	23	--	--	--
	8.3	61	129	200	110	48	43	36	35	34	27	--	--	--	36	28	26	31	30	26	--	--	--
125	2.4	28	59	100	42	38	34	27	25	26	18	--	--	--	24	21	20	22	23	19	--	--	--
	4.0	47	99	168	50	45	40	31	29	29	20	--	--	--	31	26	25	26	26	22	--	--	--
	6.0	70	149	253	77	49	44	35	33	33	25	--	--	--	35	31	29	30	31	27	--	--	--
	6.7	78	165	280	90	50	45	36	34	34	26	21	--	--	36	32	30	31	32	28	--	--	--
140	2.8	42	88	150	43	42	37	29	26	25	17	--	--	--	30	27	28	27	25	18	--	--	--
	4.0	58	124	210	50	46	40	32	29	29	21	--	--	--	33	30	32	31	29	23	--	--	--
	6.0	89	188	320	78	50	44	37	34	34	26	20	--	--	38	35	36	36	34	28	--	--	--
	7.5	111	235	400	113	51	46	39	36	36	28	22	--	--	40	37	39	38	37	31	21	--	--
160	2.6	50	106	180	43	41	36	27	25	24	-	--	--	--	29	29	28	27	26	19	--	--	--
	4.0	78	164	279	51	46	41	32	30	30	21	--	--	--	34	34	33	33	31	24	--	--	--
	6.0	116	246	418	78	49	45	36	34	34	25	20	--	--	38	38	38	37	36	29	20	--	--
	7.2	139	294	500	104	51	46	38	36	36	27	22	--	--	40	40	40	39	38	32	22	--	--
200	2.3	69	147	250	42	40	36	29	28	27	20	--	--	--	29	30	30	32	29	24	--	--	--
	4.0	122	258	439	51	47	41	33	32	30	22	--	--	--	35	36	35	35	32	27	--	--	--
	6.0	183	387	658	78	50	45	37	36	35	27	21	--	--	39	40	39	40	37	32	22	--	--
	8.2	250	529	900	133	X	X	X	X	X	X	X	X	X	X	X	X	X	X	X	X	X	X
250	2.9	139	294	500	44	45	40	32	29	27	18	--	--	--	31	34	33	27	30	23	--	--	--
	4.0	192	406	690	51	48	43	35	33	31	22	--	--	--	35	38	37	31	34	27	--	--	--
	6.0	288	609	1035	78	52	47	39	37	36	27	23	--	--	39	42	42	36	39	32	23	--	--
	8.7	417	882	1500	150	X	X	X	X	X	X	X	X	X	X	X	X	X	X	X	X	X	X
315	2.9	222	471	800	44	49	45	31	29	28	19	--	--	--	34	32	29	29	28	24	--	--	--
	4.0	306	648	1101	51	52	48	35	33	32	23	23	--	--	37	36	33	33	32	28	--	--	--
	6.0	459	971	1651	79	56	52	39	37	36	28	27	--	22	41	40	38	37	37	33	21	--	--
	10.2	778	1647	2800	210	X	X	X	X	X	X	X	X	X	X	X	X	X	X	X	X	X	X
400	2.2	278	588	1000	42	48	44	32	31	31	22	21	--	--	35	32	31	32	33	27	--	--	--
	4.0	495	1049	1783	51	53	48	36	34	34	24	24	--	--	41	37	34	35	36	30	--	--	--
	6.0	743	1573	2674	79	57	52	40	39	38	29	28	21	23	45	42	39	40	41	35	24	--	--
	9.0	1111	2353	4000	161	X	X	X	X	X	X	X	X	X	X	X	X	X	X	X	X	X	X

- Sound data is determined in a reverberation room at an independent sound laboratory, according to ISO3741 and ISO 5135 standards.
- L_w in dB/Oct. (re 1pW) are sound power levels for discharge sound and case radiated sound. Figures less than 17 dB are indicated by "-".
- The discharge sound pressure levels are determined with the assumptions as mentioned in table 1 for downstream ductwork including a diffuser with insulated plenum box.
- The radiated sound pressure levels are determined with the assumptions as mentioned in table 1 for ceiling plenum and suspended ceiling absorption.

- Lp values are including a room absorption of 10 dB/Oct.
- DB(A), NC and NR index figures are sound pressure levels. Figures less than 20 are indicated by "-".
- Δp_s is static pressure drop across VAV air volume control terminal with damper fully open.
- For non standard applications and/or selections, please contact our technical staff.

Table 1: Assumptions for additional attenuation

Hz	125	250	500	1K	2K	4K
Discharge (dB)	5	10	20	30	30	25
Radiated (dB)	2	5	10	15	15	20

Table 2: Insertion Loss

Model	125	250	500	1K	2K	4K	Hz
80	13	17	23	26	28	30	dB
100	13	17	23	26	28	30	dB
125	12	15	22	25	27	29	dB
140	12	15	22	25	27	29	dB
160	12	15	22	25	27	29	dB
200	11	15	21	24	26	28	dB
250	11	15	21	24	26	28	dB
315	8	11	21	24	26	26	dB
400	8	11	21	24	26	26	dB

Circular CAV air volume control terminals with system powered mechanical regulator

Type **NROG.VO**
NRON.VO

Sound data $\Delta p = 250$ Pa



Model	Data referring to inlet spigot				Min. Δp_s	$\Delta p = 250$ Pa																																																																																								
						Discharge sound						Radiated sound single wall																																																																																		
	Velocity		Air volume			L_w in dB/Oct. (re 1pW)						Lp values			L_w in dB/Oct. (re 1pW)						Lp values																																																																									
						125 Hz	250 Hz	500 Hz	1000 Hz	2000 Hz	4000 Hz	DB (A)	NC	NR	125 Hz	250 Hz	500 Hz	1000	2000	4000	dB (A)	NC	NR																																																																							
m/s	l/s	CFM	m ³ /h	Pa	dB						dB																																																																																			
80	2.4	11	24	40	42	42	37	31	30	31	23	--	--	--	26	20	19	23	25	20	--	--	--	4.0	19	39	67	51	50	43	36	34	34	26	20	--	--	34	27	25	28	28	23	--	--	--	6.0	28	59	100	77	53	47	40	38	38	30	24	--	--	38	31	29	32	33	28	--	--	--	7.5	35	74	125	110	55	49	42	40	40	32	26	--	21	41	33	31	35	35	30	--	--	--		
	100	2.6	19	41	70	42	44	40	33	33	33	26	--	--	--	30	23	22	28	27	23	--	--	--	4.0	29	62	106	50	50	45	37	36	35	27	21	--	--	37	28	26	31	30	25	--	--	--	6.0	44	94	160	77	54	48	41	40	39	32	24	--	--	41	33	31	35	34	30	--	--	--	8.3	61	129	200	110	55	50	43	42	41	34	26	--	21	43	35	33	38	37	33	--	--	--	
		125	2.4	28	59	100	42	45	41	34	33	33	25	--	--	--	31	27	26	28	29	26	--	--	--	4.0	47	99	168	50	52	47	38	36	36	27	23	--	--	38	33	31	32	32	28	--	--	--	6.0	70	149	253	77	56	51	42	40	40	32	27	--	22	42	37	36	37	37	33	20	--	--	6.7	78	165	280	90	57	52	43	41	41	33	28	21	23	43	38	37	38	38	34	21	--	--
			140	2.8	42	88	150	43	48	43	37	35	35	28	--	--	--	35	33	35	36	35	29	--	--	--	4.0	58	124	210	50	53	47	39	36	36	28	23	--	--	40	37	38	38	36	29	20	--	--	6.0	89	188	320	78	57	51	44	41	41	33	27	21	23	44	41	43	42	41	35	25	--	--	7.5	111	235	400	113	58	53	46	43	43	35	29	23	25	46	44	45	45	43	37	27	--
160	2.6			50	106	180	43	47	44	36	35	35	27	--	--	--	34	36	36	37	36	30	--	--	--	4.0	78	164	279	51	53	48	39	37	37	28	24	--	--	40	41	40	39	38	31	22	--	--	6.0	116	246	418	78	56	52	43	41	41	32	27	20	22	44	45	44	44	43	36	27	--	21	7.2	139	294	500	104	58	54	45	43	43	34	29	22	24	46	47	46	46	45	38	29	20	23
	200	2.3		69	147	250	42	47	43	36	35	35	27	--	--	--	35	37	37	38	36	30	--	--	--	4.0	122	258	439	51	54	48	40	39	37	30	24	--	--	42	42	41	42	39	33	24	--	--	6.0	183	387	658	78	57	52	44	43	42	34	28	22	24	46	47	46	47	44	38	28	--	22	8.2	250	529	900	133	60	55	47	46	45	38	31	25	27	49	50	49	50	48	42	32	23	26
		250	2.9	139	294	500	44	51	47	40	39	38	30	22	--	--	37	41	42	36	40	34	23	--	--	4.0	192	406	690	51	55	50	42	40	38	29	26	--	20	41	44	44	37	40	33	25	--	--	6.0	288	609	1035	78	59	54	46	44	43	34	30	23	25	46	49	48	42	45	38	30	22	24	8.7	417	882	1500	150	62	57	50	48	46	38	33	27	29	50	53	53	47	50	43	34	26	28
315			2.9	222	471	800	44	56	53	41	36	39	30	27	--	22	40	40	38	39	38	35	22	--	--	4.0	306	648	1101	51	59	55	42	40	39	30	30	24	25	44	42	40	39	39	34	23	--	--	6.0	459	971	1651	79	63	59	46	44	43	35	34	28	30	48	47	44	44	44	40	28	--	22	10.2	778	1647	2800	210	67	64	51	45	49	40	39	30	35	53	53	50	50	50	46	34	26	28
	400		2.2	278	588	1000	42	55	51	39	42	38	29	26	--	21	42	39	37	38	39	34	21	--	--	4.0	495	1049	1783	51	60	55	43	41	41	31	31	25	27	47	44	41	42	42	37	26	--	20	6.0	743	1573	2674	79	64	59	47	46	45	36	35	30	31	52	48	46	46	47	42	30	23	25	9.0	1111	2353	4000	161	68	63	51	48	50	41	39	34	35	56	53	50	51	52	47	35	28	30

- Sound data is determined in a reverberation room at an independent sound laboratory, according to ISO3741 and ISO 5135 standards.
- L_w in dB/Oct. (re 1pW) are sound power levels for discharge sound and case radiated sound. Figures less than 17 dB are indicated by "--".
- The discharge sound pressure levels are determined with the assumptions as mentioned in table 1 for downstream ductwork including a diffuser with insulated plenum box.
- The radiated sound pressure levels are determined with the assumptions as mentioned in table 1 for ceiling plenum and suspended ceiling absorption.

- Lp values are including a room absorption of 10 dB/Oct.
- DB(A), NC and NR index figures are sound pressure levels. Figures less than 20 are indicated by "--".
- Δp_s is static pressure drop across VAV air volume control terminal with damper fully open.
- For non standard applications and/or selections, please contact our technical staff.

Table 1: Assumptions for additional attenuation

Hz	125	250	500	1K	2K	4K
Discharge (dB)	5	10	20	30	30	25
Radiated (dB)	2	5	10	15	15	20

Table 2: Insertion Loss

Model	125	250	500	1K	2K	4K	Hz
80	13	17	23	26	28	30	dB
100	13	17	23	26	28	30	dB
125	12	15	22	25	27	29	dB
140	12	15	22	25	27	29	dB
160	12	15	22	25	27	29	dB
200	11	15	21	24	26	28	dB
250	11	15	21	24	26	28	dB
315	8	11	21	24	26	26	dB
400	8	11	21	24	26	26	dB

Circular CAV air volume control terminals with system powered mechanical regulator

Type **NROJ.VO**
NROQ.VO



Sound data $\Delta p = 125 \text{ Pa}$

Model	Data referring to inlet spigot				Min. Δp_s	$\Delta p = 125 \text{ Pa}$																	
	Velocity	Air volume				Discharge sound						Radiated sound single wall											
						L_w in dB/Oct. (re 1pW)						Lp values			L_w in dB/Oct. (re 1pW)						Lp values		
						125 Hz	250 Hz	500 Hz	1000 Hz	2000 Hz	4000 Hz	dB(A)	NC	NR	125 Hz	250 Hz	500 Hz	1000	2000	4000	dB(A)	NC	NR
m/s	l/s	CFM	m ³ /h	Pa	dB						dB												
80	2.4	11	24	40	42	29	23	-	-	-	-	--	--	--	20	-	-	-	18	-	--	--	--
	4.0	19	39	67	51	37	29	21	17	-	-	--	--	--	28	20	18	21	22	-	--	--	--
	6.0	28	59	100	77	40	33	25	21	19	-	--	--	--	32	24	22	26	26	21	--	--	--
	7.5	35	74	125	110	42	35	27	23	21	-	--	--	--	34	26	25	28	29	24	--	--	--
100	2.6	19	41	70	42	33	26	18	-	-	-	--	--	--	26	17	-	19	18	-	--	--	--
	4.0	29	62	106	50	37	31	22	19	-	-	--	--	--	30	22	20	24	23	18	--	--	--
	6.0	44	94	160	77	41	34	26	23	20	-	--	--	--	34	26	24	29	28	23	--	--	--
	7.5	56	118	200	110	42	36	28	25	22	-	--	--	--	36	28	26	31	30	26	--	--	--
125	2.4	28	59	100	42	32	27	19	-	-	-	--	--	--	24	21	20	22	23	19	--	--	--
	4.0	47	99	168	50	39	33	23	19	-	-	--	--	--	31	26	25	26	26	22	--	--	--
	6.0	70	149	253	77	43	37	27	23	21	-	--	--	--	35	31	29	30	31	27	--	--	--
	6.7	78	165	280	90	44	38	28	24	22	-	--	--	--	36	32	30	31	32	28	--	--	--
140	2.6	39	82	140	43	36	29	20	-	-	-	--	--	--	29	26	27	26	24	18	--	--	--
	4.0	58	124	210	50	40	33	24	19	-	-	--	--	--	33	30	32	31	29	23	--	--	--
	6.0	89	188	320	78	44	37	29	24	22	-	--	--	--	38	35	36	36	34	28	--	--	--
	7.5	111	235	400	113	45	39	31	26	24	-	--	--	--	40	37	39	38	37	31	21	--	--
160	2.6	50	106	180	43	35	29	19	-	-	-	--	--	--	29	29	28	27	26	19	--	--	--
	4.0	78	164	279	51	40	34	24	0	18	-	--	--	--	34	34	33	33	31	24	--	--	--
	6.0	116	246	418	78	43	38	28	24	22	-	--	--	--	38	38	38	37	36	29	20	--	--
	7.2	139	294	500	104	45	39	30	26	24	-	--	--	--	40	40	40	39	38	32	22	--	--
200	2.3	69	147	250	42	34	29	21	18	-	-	--	--	--	29	30	30	32	29	24	--	--	--
	4.0	122	258	439	51	41	34	25	22	18	-	--	--	--	35	36	35	35	32	27	--	--	--
	6.0	183	387	658	78	44	38	29	26	23	-	--	--	--	39	40	39	40	37	32	22	--	--
	8.2	250	529	900	133	X	X	X	X	X	X	X	X	X	X	X	X	X	X	X	X	X	X
250	2.9	139	294	500	44	39	33	24	19	-	-	--	--	--	31	34	33	27	30	23	--	--	--
	4.0	192	406	690	51	42	36	27	23	19	-	--	--	--	35	38	37	31	34	27	--	--	--
	6.0	288	609	1035	78	46	40	31	27	24	-	--	--	--	39	42	42	36	39	32	23	--	--
	8.7	417	882	1500	150	X	X	X	X	X	X	X	X	X	X	X	X	X	X	X	X	X	X
315	2.3	172	365	620	42	40	36	23	19	17	-	--	--	--	31	31	29	29	29	25	--	--	--
	4.0	306	648	1101	51	46	41	27	23	20	-	--	--	--	37	36	33	33	32	28	--	--	--
	6.0	459	971	1651	79	50	45	31	27	24	-	--	--	--	41	40	38	37	37	33	21	--	--
	6.9	528	1118	1900	98	51	46	33	28	26	17	22	--	--	43	42	39	39	39	35	23	--	--
400	3.1	389	824	1400	45	45	39	25	22	19	-	--	--	--	38	34	32	32	33	27	--	--	--
	4.0	495	1049	1783	51	47	41	28	24	22	-	--	--	--	41	37	34	35	36	30	--	--	--
	6.0	743	1573	2674	79	51	45	32	29	26	17	22	--	--	45	42	39	40	41	35	24	--	--
	7.2	889	1882	3200	105	53	47	34	31	28	19	23	--	--	47	44	41	42	43	38	26	--	21

- Sound data is determined in a reverberation room at an independent sound laboratory, according to ISO3741 and ISO 5135 standards.
- L_w in dB/Oct. (re 1pW) are sound power levels for discharge sound and case radiated sound. Figures less than 17 dB are indicated by "-".
- The discharge sound pressure levels are determined with the assumptions as mentioned in table 1 for downstream ductwork including a diffuser with insulated plenum box.
- The radiated sound pressure levels are determined with the assumptions as mentioned in table 1 for ceiling plenum and suspended ceiling absorption.

- Lp values are including a room absorption of 10 dB/Oct.
- DB(A), NC and NR index figures are sound pressure levels. Figures less than 20 are indicated by "-".
- Δp_s is static pressure drop across VAV air volume control terminal with damper fully open.
- For non standard applications and/or selections, please contact our technical staff.

Table 1: Assumptions for additional attenuation

Hz	125	250	500	1K	2K	4K
Discharge (dB)	5	10	20	30	30	25
Radiated (dB)	2	5	10	15	15	20

Table 2: Insertion Loss

Model	125	250	500	1K	2K	4K	Hz
80	13	17	23	26	28	30	dB
100	13	17	23	26	28	30	dB
125	12	15	22	25	27	29	dB
140	12	15	22	25	27	29	dB
160	12	15	22	25	27	29	dB
200	11	15	21	24	26	28	dB
250	11	15	21	24	26	28	dB
315	8	11	21	24	26	26	dB
400	8	11	21	24	26	26	dB

Circular CAV air volume control terminals with system powered mechanical regulator

Type NROJ.VO
NROQ.VO

Sound data $\Delta p = 250$ Pa



Model	Data referring to inlet spigot					$\Delta p = 250$ Pa																																																																																								
	Velocity		Air volume			Min. Δp_s	Discharge sound						Radiated sound single wall																																																																																	
							L_w in dB/Oct. (re 1pW)						Lp values			L_w in dB/Oct. (re 1pW)						Lp values																																																																								
	m/s	l/s	CFM	M ³ /h	Pa	125 Hz	250 Hz	500 Hz	1000 Hz	2000 Hz	4000 Hz	DB (A)	NC	NR	125 Hz	250 Hz	500 Hz	1000	2000	4000	dB (A)	NC	NR																																																																							
dB						dB						dB																																																																																		
80	2.4	11	24	40	42	36	30	23	20	19	-	--	--	--	26	20	19	23	25	20	--	--	--	4.0	19	39	67	51	44	36	28	24	22	-	--	--	--	34	27	25	28	28	23	--	--	--	6.0	28	59	100	77	47	40	32	28	26	18	--	--	--	38	31	29	32	33	28	--	--	--	7.5	35	74	125	110	49	42	34	30	28	20	--	--	--	41	33	31	35	35	30	--	--	--		
	100	2.6	19	41	70	42	38	33	25	23	21	-	--	--	--	30	23	22	28	27	23	--	--	--	4.0	29	62	106	50	44	38	29	26	23	-	--	--	--	37	28	26	31	30	25	--	--	--	6.0	44	94	160	77	48	41	33	30	27	20	--	--	--	41	33	31	35	34	30	--	--	--	8.3	61	129	200	110	49	43	35	32	29	22	--	--	--	43	35	33	38	37	33	--	--	--	
		125	2.4	28	59	100	42	39	34	26	23	21	-	--	--	--	31	27	26	28	29	26	--	--	--	4.0	47	99	168	50	46	40	30	26	24	-	--	--	--	38	33	31	32	32	28	--	--	--	6.0	70	149	253	77	50	44	34	30	28	20	20	--	--	42	37	36	37	37	33	20	--	--	6.7	78	165	280	90	51	45	35	31	29	21	21	--	--	43	38	37	38	38	34	21	--	--
			140	2.8	42	88	150	43	42	36	29	25	23	-	--	--	--	35	33	35	36	35	29	--	--	--	4.0	58	124	210	50	47	40	31	26	24	-	--	--	--	40	37	38	38	36	29	20	--	--	6.0	89	188	320	78	51	44	36	31	29	21	21	--	--	44	41	43	42	41	35	25	--	--	7.5	111	235	400	113	52	46	38	33	31	23	23	--	--	46	44	45	45	43	37	27	--
160	2.6			50	106	180	43	41	37	28	25	23	-	--	--	--	34	36	36	37	36	30	--	--	--	4.0	78	164	279	51	47	41	31	27	25	-	--	--	--	40	41	40	39	38	31	22	--	--	6.0	116	246	418	78	50	45	35	31	29	20	21	--	--	44	45	44	44	43	36	27	--	21	7.2	139	294	500	104	52	47	37	33	31	22	23	--	--	46	47	46	46	45	38	29	20	23
	200	2.3		69	147	250	42	41	36	28	25	23	-	--	--	--	35	37	37	38	36	30	--	--	--	4.0	122	258	439	51	48	41	32	29	25	18	--	--	--	42	42	41	42	39	33	24	--	--	6.0	183	387	658	78	51	45	36	33	30	22	22	--	--	46	47	46	47	44	38	28	--	22	8.2	250	529	900	133	54	48	39	36	33	26	25	--	--	49	50	49	50	48	42	32	23	26
		250	2.9	139	294	500	44	45	40	32	29	26	18	--	--	--	37	41	42	36	40	34	23	--	--	4.0	192	406	690	51	49	43	34	30	26	17	--	--	--	41	44	44	37	40	33	25	--	--	6.0	288	609	1035	78	53	47	38	34	31	22	23	--	--	46	49	48	42	45	38	30	22	24	8.7	417	882	1500	150	56	50	42	38	34	26	27	--	22	50	53	53	47	50	43	34	26	28
315			2.9	222	471	800	44	50	46	33	29	27	18	21	--	--	40	40	38	39	38	35	22	--	--	4.0	306	648	1101	51	53	48	34	30	27	18	24	--	--	44	42	40	39	39	34	23	--	--	6.0	459	971	1651	79	57	52	38	34	31	23	28	21	23	48	47	44	44	44	40	28	--	22	10.2	778	1647	2800	210	61	57	43	35	37	28	32	27	28	53	53	50	50	45	46	34	26	28
	400		2.2	278	588	1000	42	49	44	31	28	26	17	--	--	--	42	39	37	38	39	34	21	--	--	4.0	495	1049	1783	51	54	48	35	31	29	19	25	--	--	47	44	41	42	42	37	26	--	20	6.0	743	1573	2674	79	58	52	39	36	33	24	29	22	24	52	48	46	46	47	42	30	23	25	9.0	1111	2353	4000	161	62	56	43	40	38	29	32	27	28	56	53	50	51	52	47	35	28	30

1. Sound data is determined in a reverberation room at an independent sound laboratory, according to ISO3741 and ISO 5135 standards.
2. L_w in dB/Oct. (re 1pW) are sound power levels for discharge sound and case radiated sound. Figures less than 17 dB are indicated by "--".
3. The discharge sound pressure levels are determined with the assumptions as mentioned in table 1 for downstream ductwork including a diffuser with insulated plenum box.
4. The radiated sound pressure levels are determined with the assumptions as mentioned in table 1 for ceiling plenum and suspended ceiling absorption.

5. Lp values are including a room absorption of 10 dB/Oct.
6. DB(A), NC and NR index figures are sound pressure levels. Figures less than 20 are indicated by "--".
7. Δp_s is static pressure drop across VAV air volume control terminal with damper fully open.
8. For non standard applications and/or selections, please contact our technical staff.

Table 1: Assumptions for additional attenuation

Hz	125	250	500	1K	2K	4K
Discharge (dB)	5	10	20	30	30	25
Radiated (dB)	2	5	10	15	15	20

Table 2: Insertion Loss

Model	125	250	500	1K	2K	4K	Hz
80	13	17	23	26	28	30	dB
100	13	17	23	26	28	30	dB
125	12	15	22	25	27	29	dB
140	12	15	22	25	27	29	dB
160	12	15	22	25	27	29	dB
200	11	15	21	24	26	28	dB
250	11	15	21	24	26	28	dB
315	8	11	21	24	26	26	dB
400	8	11	21	24	26	26	dB

