

## CSV/CSH Linear Jet Flow Type Diffusers

# CSV/CSH Linear Jet Flow Type Diffusers

## *Table of Contents*

<b>Description</b>	<b>Page</b>
Energy Saving Air Distribution	2
Slim and stylish appearance	3
Fixed and removable diffuser inserts	4
Supply and Return Air Diffusers	4
Anti-Condensation Options	5
Anti-condensation diffusers	5
Anti-Condensation Plenums	5
Dimensions	6
Air Connectors (defined by flexible hose connector size)	6
Ceiling Type CSV Series Jet-Flow Selection Procedure:	7-8

# CSV/CSH Linear Jet Flow Type Diffusers

## Energy Saving Air Distribution

Barcol-Air JET-FLOW linear air distribution is designed to meet the demands of the move towards more energy efficient buildings using less air to save energy. These ultra slim diffusers are designed with multi directional air jets to maximise the amount of air mixing outside of the comfort zone using low airflows to save energy.

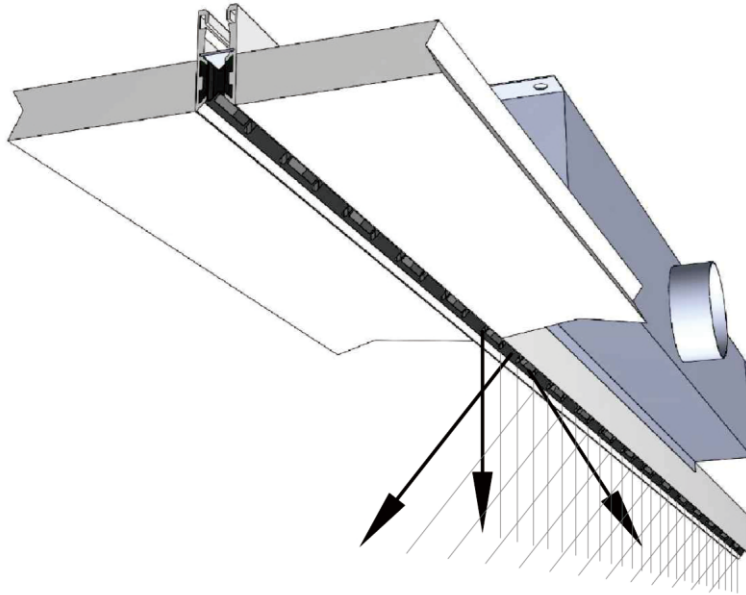

This ensures the air mixing with the room air is complete above the comfort zone to ensure the comfort in the occupied area.

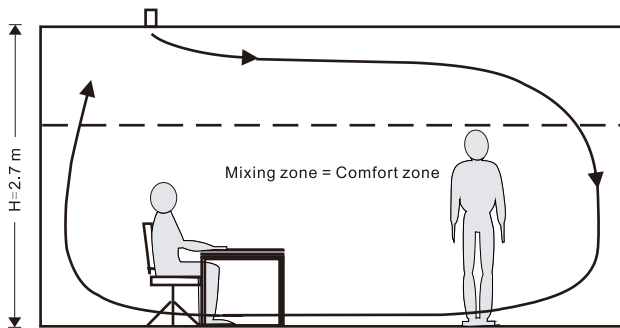

Normal Diffuser

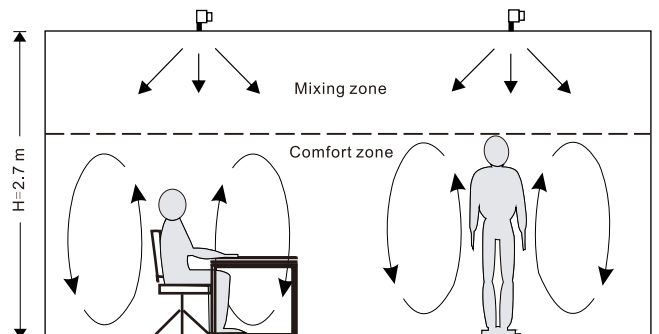

Barcolair Linear Jet Flow Type Diffusers

# CSV/CSH Linear Jet Flow Type Diffusers Features

## **Slim and stylish appearance**

Barcol-Air JET-FLOW design is based on a very narrow width slot only 23.5mm wide and has a very stylish appearance blending in with the ceiling design.



# CSV/CSH Linear Jet Flow Type Diffusers Features

## Fixed and removable diffuser inserts

Barcol-Air JET-FLOW diffusers are available with Fixed or Removable diffuser inserts allowing the diffuser bodies to be installed with the ceiling and for the diffuser inserts to be installed later during the commissioning period. This avoids damage to the inserts and also allows for the air ducting to be flushed of any construction debris before the inserts are installed.

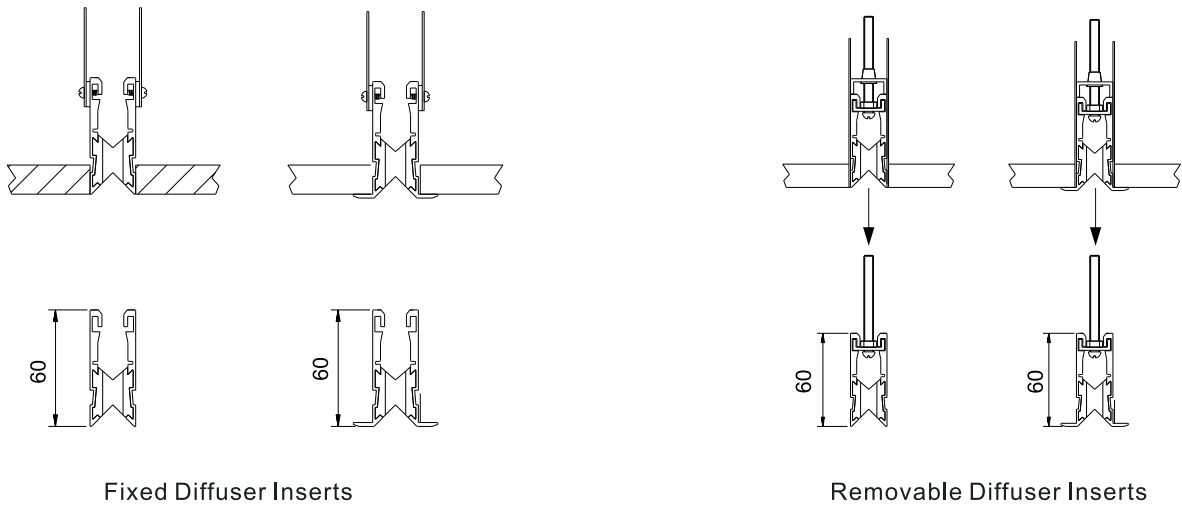

The removable diffusers are attached to the diffuser body with location screws which hold the inserts firmly in place between the diffuser side plates. This allows for the inserts to also be easily removed for cleaning.

## Supply and Return Air Diffusers

Barcol-Air JET-FLOW diffusers are supplied complete with air plenums for supply or return air applications or without plenums for ceiling void air return air or as dummy diffusers to provide continuous lengths of diffuser for enhanced appearance.

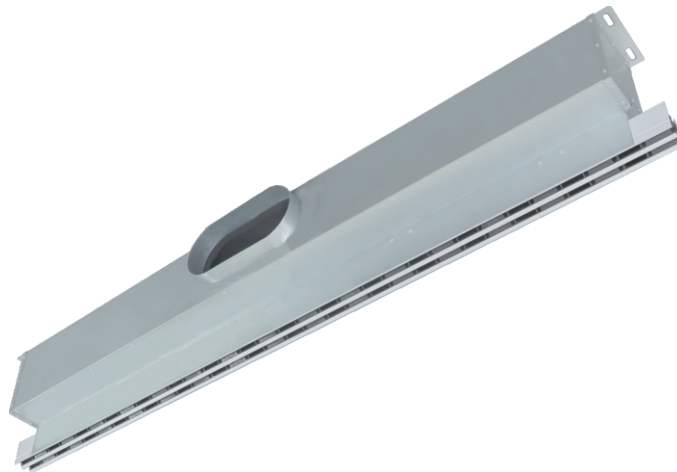

# CSV/CSH Linear Jet Flow Type Diffusers Features

## Anti-Condensation Options

Condensation on diffusers or their supply air plenums can result in convenient condensate dripping and damage to decoration. Barcol-Air CSV JET-FLOW diffusers are available with the following options to eliminate condensations in applications where this is a risk.

### Anti-condensation diffusers





With this option the diffusers are constructed from non-metallic materials for both the side plates as well as the air direction inserts. This avoids low temperature metal surfaces at the outlet which cause condensation on the diffuser. These allow for the supply air temperature to be up to 4 deg C below the room dewpoint temperature eliminating condensation.

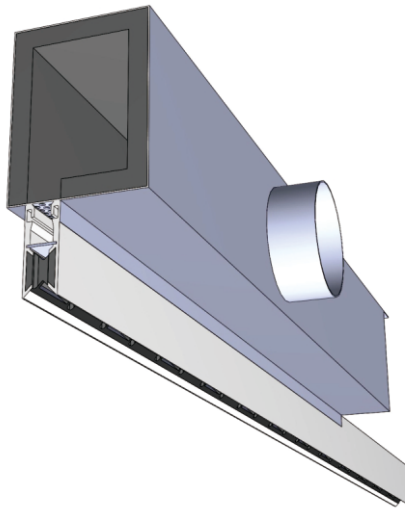

### Anti-Condensation Plenums

The Anti-Condensation plenums are available internally insulated with closed cell elastomeric insulation to prevent condensation on the air plenum. Various insulation thicknesses are available to meet the severity of the condensation risk.



## CSV/CSH Linear Jet Flow Type Diffusers Features

CSV-3 Way Linear Jet Flow Type Diffusers			
1 Slot	2 Slot	3 Slot	4 Slot
			

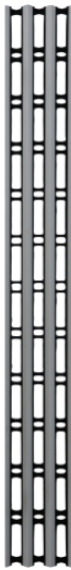
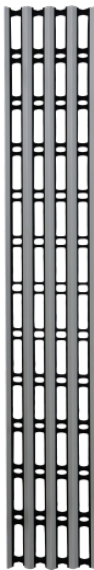
CSH-1 Way Linear Jet Flow Type Diffusers			
1 slot	2 Slot	3 Slot	4 Slot
			

# Ceiling Type CSV/CSH Series Jet Flow Diffusers

## Dimensions

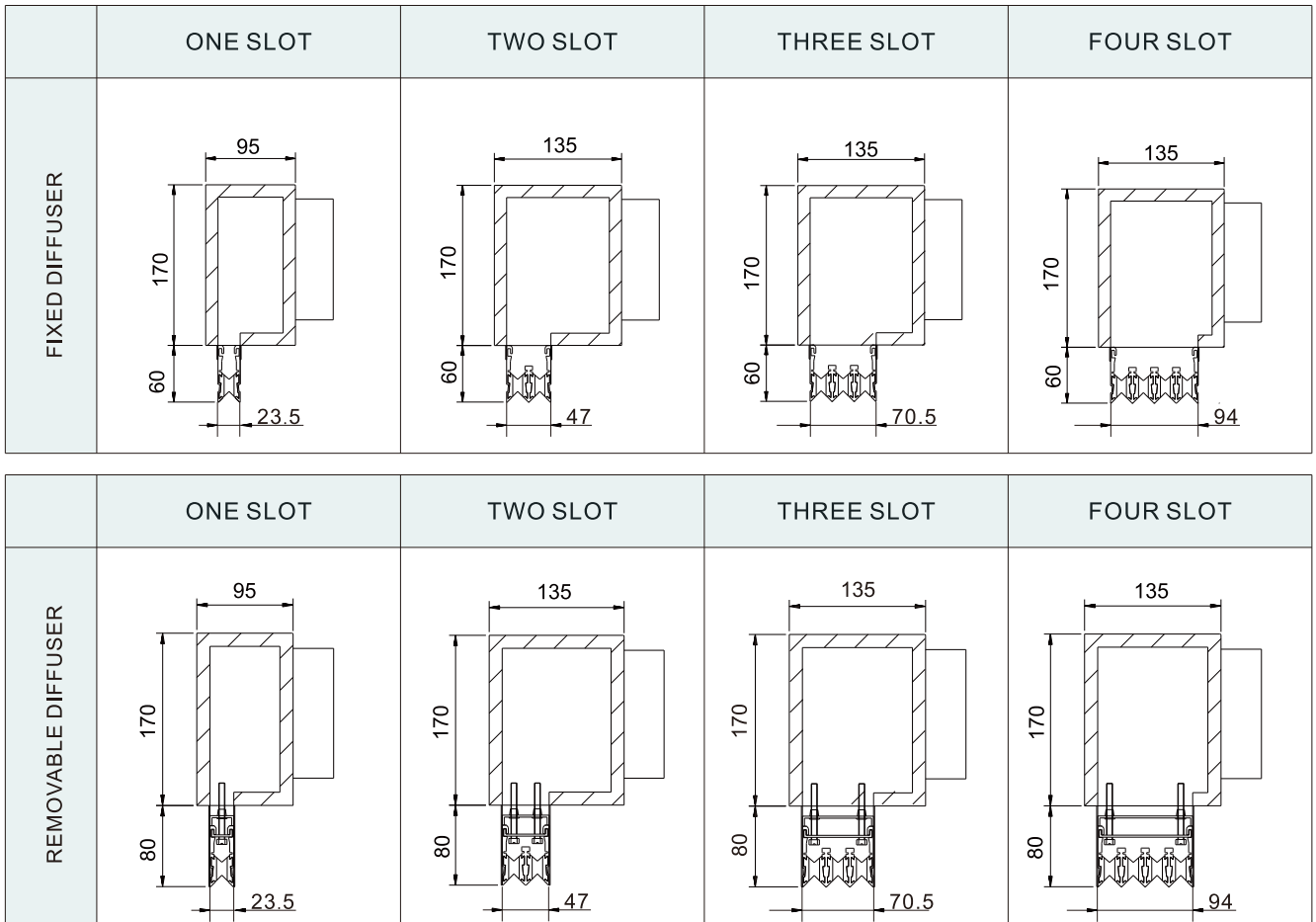

## Air Connectors defined by flexible hose connector size (Static pressure : 20Pa )

ACTIVE LENGTH	ONE SLOT	TWO SLOT	THREE SLOT	FOUR SLOT
900 mm	1 x 125 mm dia	1 x 160 mm dia	1 x 200 mm dia	2 x 160 mm dia
1200 mm	1 x 125 mm dia	1 x 200 mm dia	2 x 160 mm dia	2 x 200 mm dia
1500 mm	1 x 160 mm dia	1 x 200 mm dia	2 x 200 mm dia	2 x 200 mm dia
1800 mm	1 x 160 mm dia	2 x 160 mm dia	2 x 200 mm dia	2 x 200 mm dia

CONNECTOR NAME	DIMENSIONS	
125 mm dia	125 mm dia ROUND	
160 mm dia	160 mm dia EQUIVALENT OVAL	
200 mm dia	200 mm dia EQUIVALENT OVAL	

# Ceiling Type CSV/CSH Series Jet-Flow selection Procedure

The CSV/CSH Jet-Flow Diffuser's length and number of slots should be selected to match the required supply air plenum pressure and required air Volume as follows:

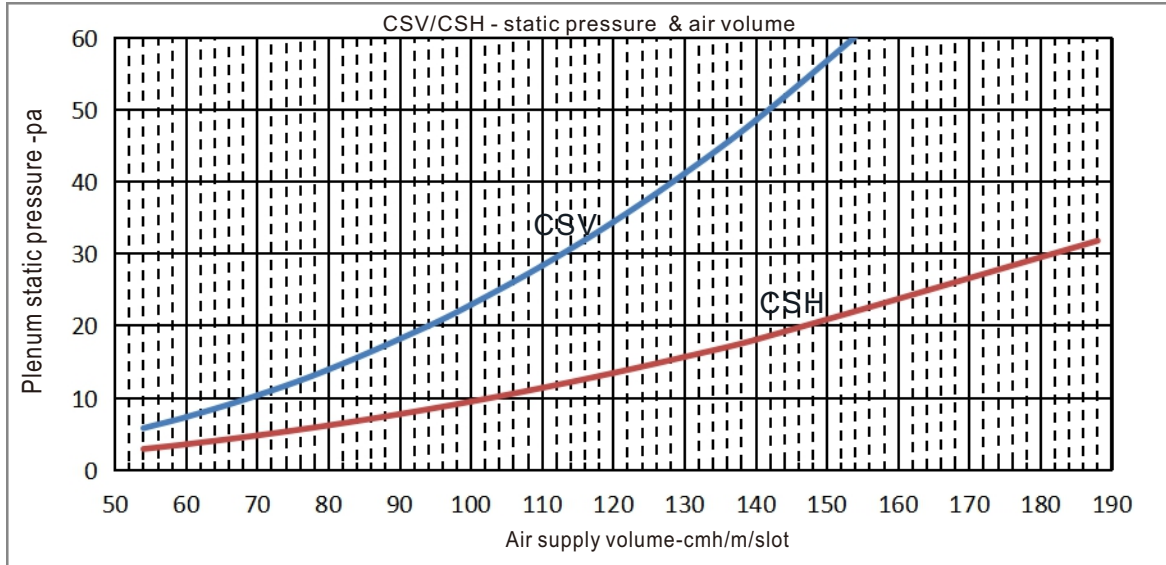

Example:

Select Active Diffuser length and number of slots for diffuser to supply 280 CMH with plenum pressure of about 20 Pa.

- From Chart 1. Read Airflow with 20 Pa plenum pressure equals 94 CMH/meter length/slot.
- Determine required active diffuser lengths (plenum lengths) are:
  - 1 slot  $280/94/1 = 2.98\text{m}$
  - 2 slot  $280/94/2 = 1.49\text{m}$
  - 3 slot  $280/94/3 = 0.99\text{m}$
  - 4 slot  $280/94/4 = 0.74\text{m}$
- Choose 2 slot diffuser with 1.49m active length.  
 Airflow CMH/meter length/slot =  $280 / 1.49 / 2 = 94$   
 From Chart 1 required plenum pressure equals 20 Pa.

# Ceiling Type CSV/CSH Series Jet-Flow selection Procedure

CSV ONE SLOT									
Plenum Pressure	Pa	6	10	15	20	30	40	50	
Airflow	m <sup>3</sup> /h per m length	54	70	80	94	114	127	141	
Air Velocity	m/s	X = 0.1m	0.024	0.031	0.038	0.046	0.054	0.058	0.061
		X = 1.1m	0.035	0.061	0.065	0.068	0.071	0.078	0.086
		X = 1.6m	0.062	0.074	0.076	0.087	0.092	0.098	0.122
Sound Pressure Level	Lp(A)	21.9	21.9	23.3	24.7	29.3	32.8	36.7	
	NC	16	16	16	17	23	28	33	
CSV TWO SLOTS									
Plenum Pressure	Pa	6	10	15	20	30	40	50	
Airflow	m <sup>3</sup> /h per m length	107	138	163	187	225	253	283	
Air Velocity	m/s	X = 0.1m	0.025	0.034	0.043	0.044	0.045	0.052	0.060
		X = 1.1m	0.036	0.055	0.063	0.070	0.074	0.082	0.085
		X = 1.6m	0.068	0.085	0.094	0.100	0.104	0.115	0.131
Sound Pressure Level	Lp(A)	20.6	21.1	23.4	26.3	31.5	35.8	40.2	
	NC	16	16	16	21	26	31	36	
CSV THREE SLOTS									
Plenum Pressure	Pa	6	10	15	20	30	40	50	
Airflow	m <sup>3</sup> /h per m length	163	208	245	283	343	393	437	
Air Velocity	m/s	X = 0.1m	0.021	0.030	0.045	0.050	0.052	0.054	0.068
		X = 1.1m	0.034	0.056	0.060	0.065	0.070	0.088	0.090
		X = 1.6m	0.068	0.080	0.082	0.098	0.110	0.120	0.135
Sound Pressure Level	Lp(A)	21.3	23.4	28.4	33.5	37.6	41.4	45.3	
	NC	16	16	21	26	31	36	40	
CSV FOUR SLOTS									
Plenum Pressure	Pa	6	10	15	20	30	40	50	
Airflow	m <sup>3</sup> /h per m length	212	269	324	374	452	516	577	
Air Velocity	m/s	X = 0.1m	0.025	0.025	0.035	0.038	0.045	0.055	0.066
		X = 1.1m	0.040	0.060	0.062	0.068	0.072	0.098	0.102
		X = 1.6m	0.080	0.090	0.085	0.112	0.120	0.124	0.140
Sound Pressure Level	Lp(A)	22.5	24.4	30.6	35.3	40.5	44.1	48.5	
	NC	16	17	23	28	36	39	44	

## Notes:

1. Air Diffusers installed 2.7m above floor level.
2. Air plenums insulated with 13mm thick internal elastomeric insulation.
3. Air velocities measured in line with centre line of diffuser.
4. X is distance of air velocity measurement above floor level.

