

NM Series

**Rectangular CAV air volume control terminals
with system powered mechanical regular**



Rectangular CAV air volume control terminals with system powered mechanical regulator Table of contents

Description	Page
Type designation	2
Technical data	
- General	3
- Specification	4
- Installation instructions	5
Model overview / dimensions	6
Sound data NMOAOVO	7-8

Rectangular CAV air volume control terminals with system powered mechanical regulator

Type designation
Single wall (type NM...)

Composition type designation:

N - M - O - A - O - O

N Position 1: **Product group**

Ordering example:

M Position 2: **Function**

O=not applicable
M=rectangular CAV terminal, single wall construction
1= non standard, specify separately

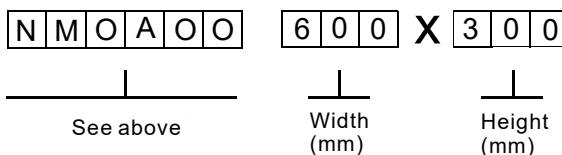

O Position 3: **Control**

0 = system powered regulator (standard)
1 = non standard, specify separately

A Position 4: **Outlet**

O=not applicable
A= rectangular outlet
1= non standard, specify separately

O Position 5: **Reheat coil**

O=without reheat coil
A=1-row hot water reheat
B=2-row hot water reheat
D=4-row hot water reheat
E=1-stage 230VAC/1-phase electric reheat coil
F=2-stage 230VAC/1-phase electric reheat coil
G=3-stage 230VAC/1-phase electric reheat coil
1=non standard specify separately

O Position 6: **Finish**

O=standard finish (galvanised steel)
P=powder paint coating
s=SUS304+Aluminum painting
None=standard finish (Galvanised steel)

Ordering information:

Standard terminals:

- quantity of terminals
- complete 6 digit code
- terminal size or model
- air volume setting (Q)

Non standard terminals:

- for non standard terminals a full description and/or drawing are requested

Rectangular CAV air volume control terminals with system powered mechanical regulator

Type designation
Single wall (type NM...)

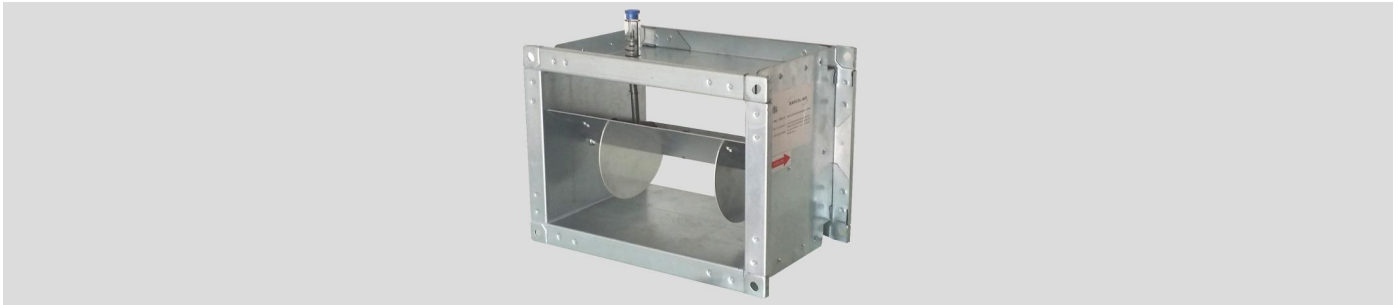

Application

NM series of rectangular, constant volume terminals with system powered mechanical regulator are designed to keep a constant air flow, independent of the inlet static pressure without the use of a DDC CAV/VAV controller/actuator. These terminals save commissioning time on site and are suitable either for supply or return air in new or refurbishment projects.

Features:

- Single wall or double wall.
- Pressure independent from 80 – 1000 Pa.
- Compact design.
- Low pressure loss over the terminal.
- Control accuracy $\pm 10\%$.
- Temperature insensitive (-15°C to $+100^{\circ}\text{C}$).
- Can be mounted in any position.
- Factory setting of airflow rate.
- Provision for on-site adjustment of airflow setting.
- Maintenance free.
- Low noise production.

Technical information

Casing:

Terminal casing made of galvanized sheet steel with option for stainless steel both with flange duct connections. Casing leakage is class C according to standard EN1751 except models NM 200mm x 100mm which are class B connections are 30mm wide. In case of double wall construction 25 mm insulation material is used completely enclosed by the double wall sheet metal construction.

Damper:

Damper blade: aluminum.
Damper shaft: steel with self lubricating nylon bearings.

Controls:

- The factory setpoint is indicated on the terminal.

Finish:

- Standard finish galvanized steel with option for stainless steel.
- Optional finish with powder painting is available upon request.

Delivery format

Delivery format:

- When ordering, the required air volume must be indicated.

Rectangular CAV air volume control terminals with system powered mechanical regulator

Type designation
Single wall (type NM...)

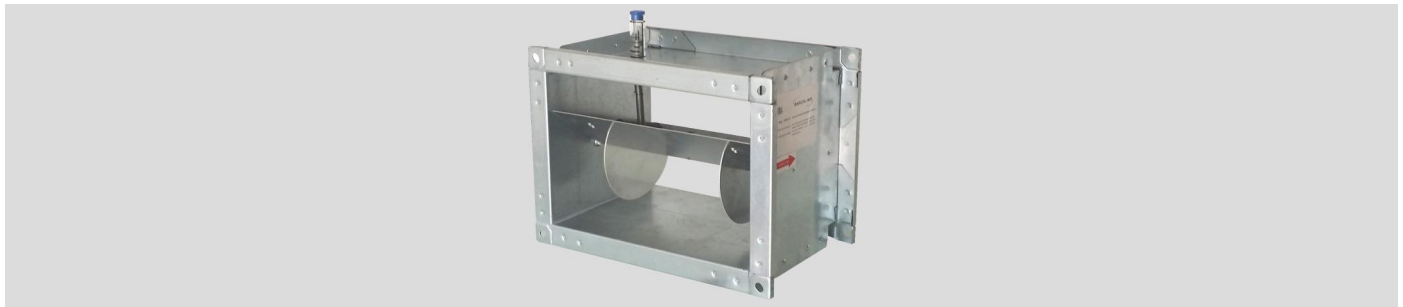

Specify as:

Example:

Supply and install, rectangular, pressure independent constant air volume terminals with system powered mechanical regulator and control accuracy $\pm 10\%$.

The construction shall be galvanized steel with a casing leakage rate classified as class C according to standard EN1751 except models NM 200mm x 100mm which are class B. The CAV terminals shall have an aluminum damper blade with steel shaft rotating in self lubricating nylon bearings.

Air volume 360 l/s

Terminal size 300 x 200 mm

Max. pressure loss 60 Pa

Max. discharge sound index < NC35

(@250Pa Δp)

Max. radiated sound index < NC35

@250Pa Δp)

Required air volume to be factory set with provision for on-site adjustment (Barcol-Air type NMOAOVO).

Ordering example: type - model - airflow (m3/h) = NMOAOVO - 3020 - Q1296 (= 1296 m3/h)

Manufacturer: Barcol-Air

Model H×W	Recommended air volume								
	l/s			CFM			m3/h		
	Min		Max	Min		Max	Min		Max
100×200	60	-	180	127	-	381	216	-	648
150×200	90	-	270	191	-	572	324	-	972
150×300	135	-	405	286	-	858	486	-	1458
200×200	120	-	360	254	-	763	432	-	1296
200×300	180	-	540	381	-	1144	648	-	1944
200×400	240	-	720	508	-	1525	864	-	2592
250×300	225	-	675	477	-	1430	810	-	2430
250×400	300	-	900	636	-	1907	1080	-	3240
250×500	375	-	1125	794	-	2383	1350	-	4050
300×300	270	-	810	572	-	1716	972	-	2916
300×400	360	-	1080	763	-	2288	1296	-	3888
300×500	450	-	1350	953	-	2860	1620	-	4860
300×600	540	-	1620	1144	-	3432	1944	-	5832
400×400	480	-	1440	1017	-	3051	1728	-	5184
400×500	600	-	1800	1271	-	3814	2160	-	6480
400×600	720	-	2160	1525	-	4576	2592	-	7776
500×500	750	-	2250	1589	-	4767	2700	-	8100
500×600	900	-	2700	1907	-	5720	3240	-	9720
500×800	1200	-	3600	2542	-	7627	4320	-	12960
600×600	1080	-	3240	2288	-	6864	3888	-	11664
600×800	1440	-	4320	3051	-	9153	5184	-	15552
600×1000	1800	-	5400	3814	-	11441	6480	-	19440
600×1200	2160	-	6480	4576	-	13729	7776	-	23328

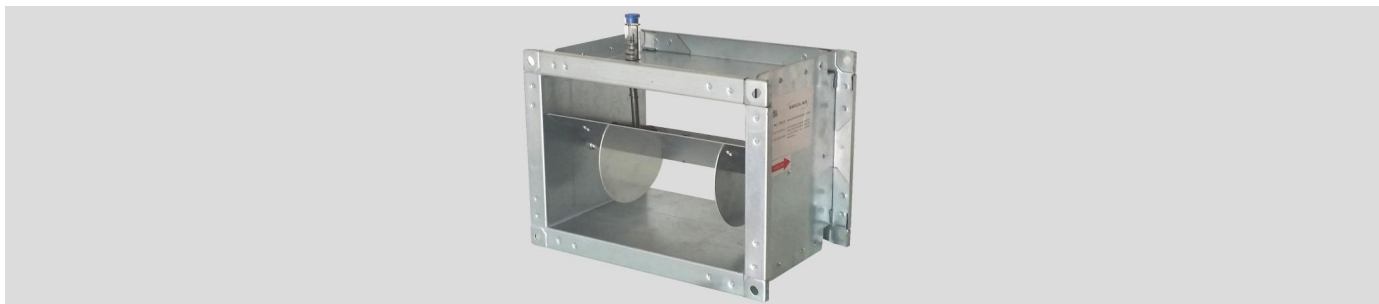

Installation Instructions:

The Barcol-Air CAV terminals shall be installed in, and supported by the rectangular connecting ducts. The ducts shall be supported either side of the CAV using at least two support channels with anti-vibration rubber between the support channels and ducting to prevent vibration and to avoid a thermal bridge. Each of the support channels shall be fixed with threaded rods to the ceiling slab above. Alternatively, the ducting and units can be suspended using hanger brackets as shown in the drawing below.

This installation method:

1. Shall prevent the body of the CAV terminal from high mechanical tension, which could damage the construction and performance of the terminal.
2. Shall prevent torsion on the CAV terminals, which could cause malfunction of the damper blades.
3. Provides some flexibility to the final location of the CAV terminals.
4. Use at least one equivalent diameter straight duct length with the same width and height as the CAV terminal before CAV inlet.
Equivalent diameter = $\sqrt{(4 \times W \times H) / \pi}$
5. Additional manual volume control dampers (VCD's) before the inlet are not required or recommended!
6. All connections shall be thermally isolated.

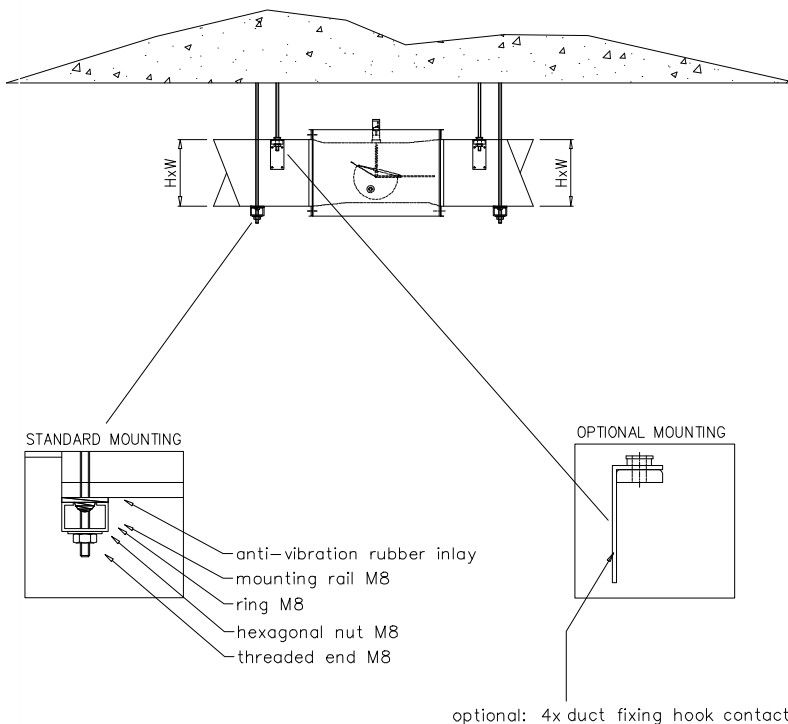

Rectangular CAV air volume control terminals with system powered mechanical regulator

Model overview
Single wall(type NM...)

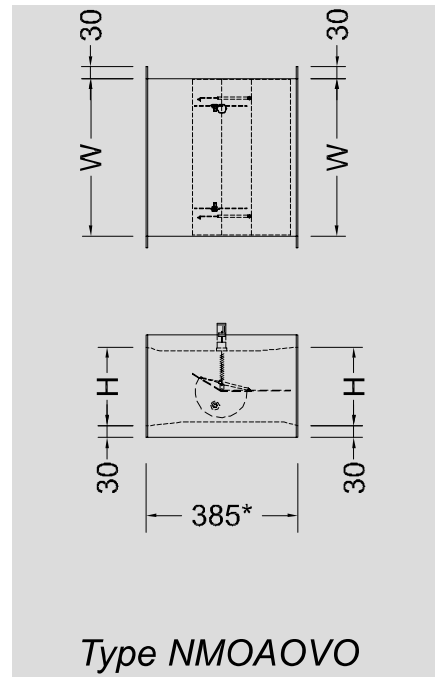
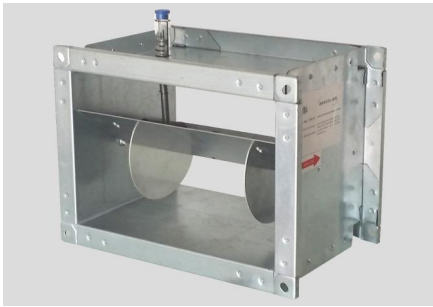

* = Installed Length.

Dimensions

Height (H)	Width(W)												Length (L)
	100	200	300	400	500	600	800	1000	1200	1400	1600	1800	
100		●											220
150	★	★	●										220
200		●	●	●	★	★	★						220
250			●	●	●	★	★	★					270
300			●	●	●	●	★	★	★				320
400				●	●	●	★	★	★	★	★		380
500					●	●	●	★	★				425
600						●	●	●	●	★	★	★	475

Remark: All dimension based on mm

● Stand for Standard model

★ Stand for non standard

Non standard model please contact our sales

Rectangular CAV air volume control terminals with system powered mechanical regulator

Type NMOA00

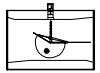

Sound data $\Delta p = 125 \text{ Pa}$

Model (HxW)	data referring to inlet spigot				min. ΔP_s	$\Delta P = 125 \text{ Pa}$																		
						discharge sound						radiated sound												
	velocity	air volume				Pa	Lwin dB/Oct(re 1pW)						Lp values			Lwin dB/Oct(re 1pW)						Lp values		
							125Hz	250Hz	500Hz	1000Hz	2000Hz	4000Hz	dB(A)	NC	NR	125Hz	250Hz	500Hz	1000Hz	2000Hz	4000Hz	dB(A)	NC	NR
	m/s	l/s	CFM	m3/h		dB						dB												
100x200	2.8	56	119	202	68	49	48	46	44	42	39	22	—	—	47	46	45	44	43	42	21	—	—	
	6.0	120	254	432	100	55	54	52	51	49	48	28	21	24	53	52	50	49	48	46	26	—	—	
	9.7	194	411	698	199	58	56	55	53	51	49	31	23	26	56	54	53	52	50	47	29	21	23	
150x200	3.0	90	191	324	71	52	51	50	48	47	45	27	—	23	51	52	51	48	46	45	27	—	23	
	6.0	180	381	648	100	57	56	56	53	50	49	32	22	26	58	56	53	52	50	49	31	23	26	
	9.0	270	572	972	175	63	62	60	57	55	52	36	28	32	61	59	55	55	53	50	33	24	27	
150x300	3.0	135	286	486	71	53	52	51	50	48	46	28	—	24	53	52	51	50	48	46	28	—	24	
	6.0	270	572	972	100	59	57	56	54	52	50	32	24	27	59	57	56	54	52	50	32	24	27	
	9.0	405	857	1458	175	64	62	60	58	56	53	37	30	32	62	60	58	56	54	52	33	26	28	
200x200	3.0	120	254	432	71	52	51	49	47	45	42	25	—	20	50	49	48	47	46	42	23	—	—	
	6.0	240	508	864	100	58	56	55	53	51	49	31	23	26	56	54	53	52	50	47	29	21	23	
	9.0	360	762	1296	175	63	62	60	58	55	53	37	30	32	60	58	57	56	53	50	33	26	28	
200x300	3.0	180	381	648	71	54	52	50	48	46	43	27	—	23	52	50	48	47	45	42	25	—	—	
	6.0	360	762	1296	100	59	58	56	54	52	50	32	26	28	57	56	54	52	51	48	30	24	25	
	9.0	540	1143	1944	175	65	63	62	59	58	54	38	30	33	62	60	59	57	55	53	34	28	29	
200x400	3.0	240	508	864	71	54	53	51	49	47	44	28	—	23	52	51	49	47	45	43	25	—	21	
	6.0	480	1016	1728	100	60	58	57	55	53	50	33	26	28	58	56	55	53	51	48	31	24	26	
	9.0	720	1524	2592	175	65	64	63	60	58	54	39	30	34	63	61	59	57	55	53	35	28	30	
250x300	3.0	225	476	810	71	53	52	50	49	47	44	26	—	21	51	49	47	46	45	43	23	—	—	
	6.0	450	953	1620	100	59	58	56	54	53	50	32	24	27	57	56	54	52	51	49	30	22	25	
	9.0	675	1429	2430	175	65	64	63	60	58	54	39	30	34	63	61	59	57	55	53	35	28	30	
250x400	3.0	300	635	1080	71	54	53	51	49	47	44	28	—	23	52	51	49	47	46	43	25	—	21	
	6.0	600	1270	2160	100	60	58	57	55	53	50	33	26	28	58	57	55	54	52	50	30	23	25	
	9.0	900	1906	3240	175	65	64	63	62	60	56	39	31	35	64	62	60	59	57	55	35	28	32	
250x500	3.0	375	794	1350	71	55	54	53	52	50	48	29	22	24	53	51	50	48	46	45	27	20	21	
	6.0	750	1588	2700	100	61	58	56	55	52	50	34	26	28	59	57	55	53	52	50	31	23	25	
	9.0	1125	2382	4050	175	66	65	64	62	60	56	39	31	35	64	62	60	59	57	55	35	28	32	
300x300	3.0	270	572	972	71	55	54	52	49	47	45	29	—	23	53	51	49	48	46	43	26	—	20	
	6.0	540	1143	1944	100	60	59	57	56	53	51	33	27	29	58	56	55	53	51	50	30	24	26	
	9.0	810	1715	2916	175	65	64	62	59	56	53	37	30	32	62	60	58	57	55	51	33	26	28	
300x400	3.0	360	762	1296	71	56	54	52	50	47	45	29	21	24	54	52	51	49	48	46	26	—	21	
	6.0	720	1524	2592	100	62	60	59	57	54	52	35	28	30	60	58	56	54	53	50	32	25	27	
	9.0	1080	2287	3888	175	67	66	64	62	60	56	39	31	35	64	62	60	59	57	55	35	28	32	
300x500	3.0	450	953	1620	71	56	55	53	51	48	46	30	22	26	54	53	51	50	48	43	27	—	22	
	6.0	900	1906	3240	100	62	61	60	58	55	53	36	29	31	60	59	57	56	55	53	33	26	28	
	9.0	1350	2858	4860	175	67	65	64	63	61	56	39	31	36	65	63	62	60	58	55	35	27	32	
300x600	3.0	540	1143	1944	71	57	55	53	51	48	45	30	22	25	55	54	53	51	49	42	27	—	21	
	6.0	1080	2287	3888	100	62	61	59	57	55	52	35	29	31	60	58	56	55	53	50	32	26	28	
	9.0	1620	3430	5832	175	67	66	64	63	61	58	40	31	39	65	63	62	60	58	55	35	27	32	
400x400	3.0	480	1016	1728	71	57	55	53	51	48	45	30	22	25	55	53	52	50	48	43	28	—	22	
	6.0	960	2033	3456	100	62	61	59	57	55	52	35	29	31	60	58	57	56	53	50	32	26	28	
	9.0	1440	3049	5184	175	68	67	64	63	61	58	39	31	38	65	63	62	60	58	55	35	27	32	
400x500	3.0	600	1270	2160	71	58	56	53	51	48	45	33	27	29	56	54	53	50	47	43	30	24	25	
	6.0	1200	2541	4320	100	63	62	60	58	55	53	37	30	32	60	58	57	56	53	50	33	26	28	
	9.0	1800	3811	6480	175	68	67	65	63	61	59	39	32	38	66	64	62	61	59	56	35	27	32	
400x600	3.0	720	1524	2592	71	58	57	54	52	49	46	34	28	30	56	54	52	51	48	43	30	25	27	
	6.0	1440	3049	5184	100	63	62	61	59	56	54	38	31	33	60	58	57	56	54	51	35	28	30	
	9.0	2160	4573	7776	175	69	69	67	65	63	61	38	32	38	66	64	62	61	59	56	35	27	32	
500x500	3.0	750	1588	2700	71	58	56	54	52	49	46	31	23	26	56	54	53	51	49	45	28	20	23	
	6.0	1500	3176	5400	100	64	62	60	58	56	53	37	30	32	62	60	58	56	54	52	33	26	28	
	9.0	2250	4764	8100	175	70	68	67	66	65	63	45	38	46	68	66	65	63	61	60	40	33	42	
500x600	3.0	900	1906	3240	71	59	57	55	52	49	46	32	24	27	57	55	53	50	48	45	29	21	24	
	6.0	1800	3811	6480	100	64	63	61	58	56	53	37	30	32	62	60	58	57	55	51	33	26	28	
	9.0	2700	5717	9720	175	70	68	67	66	65	63	45	38	46	68	66	65	63	61	60	40	33	42	
500x800	3.0	1200	2541	4320	71	59	58	56	53	50	48	33	25	28	57	55	54	53	49	45	30	22	24	
	6.0	2400	5081	8640	100	65	63	62	59	58	54	38	30	33	62	60	59	57	55	53	34	28	29	
	9.0	3600	7622	12960	175	71	70	68	67	64	61	44	38	47	69	68	66	65	63	61	40	34	41	
600x600	3.0	1080	2287	3888	71	59	58	57	54	50	49	33	26	29	57	55	53	51						

Rectangular CAV air volume control terminals with system powered mechanical regulator

Type NMOA00

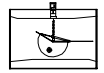

Sound data $\Delta p = 250 \text{ Pa}$

Model (HxW)	data referring to inlet spigot				min. ΔP_s	$\Delta P=250\text{Pa}$																		
						discharge sound						radiated sound												
	velocity		air volume			Pa	Lw in dB/Oct (re 1pW)						Lp values			Lw in dB/Oct (re 1pW)						Lp values		
							125Hz	250Hz	500Hz	1000Hz	2000Hz	4000Hz	dB(A)	NC	NR	125Hz	250Hz	500Hz	1000Hz	2000Hz	4000Hz	dB(A)	NC	NR
m/s	l/s	CFM	m ³ /h	dB																				
100x200	2.8	56	119	202	68	55	54	52	49	47	45	29	—	23	53	51	49	48	46	43	26	—	20	
	6.0	120	254	432	100	61	58	56	55	52	50	34	26	28	59	57	55	53	52	50	31	23	25	
	9.7	194	411	698	199	65	64	62	59	56	53	37	30	32	62	60	58	57	55	51	33	26	28	
150x200	3.0	90	191	324	71	58	56	55	52	51	49	31	23	26	57	57	56	52	50	49	31	23	26	
	6.0	180	381	648	100	61	61	60	57	53	52	37	28	31	59	57	54	54	51	49	32	25	27	
	9.0	270	572	972	175	66	66	64	61	59	55	38	29	35	63	61	57	58	56	53	35	26	31	
150x300	3.0	135	286	486	71	59	57	56	54	52	50	32	24	27	59	57	56	54	52	50	32	24	27	
	6.0	270	572	972	100	63	62	60	58	55	53	37	30	32	60	58	57	56	53	50	33	26	28	
	9.0	405	857	1458	175	67	66	64	62	60	56	39	31	35	64	62	60	59	57	55	35	28	32	
200x200	3.0	120	254	432	71	58	57	54	52	49	46	34	28	30	56	54	52	51	48	43	30	25	27	
	6.0	240	508	864	100	64	62	60	58	56	53	37	30	32	62	60	58	56	54	52	33	26	28	
	9.0	360	762	1296	175	66	65	64	62	60	56	39	31	35	64	62	60	59	57	55	35	28	32	
200x300	3.0	180	381	648	71	60	58	57	55	53	50	33	26	28	58	56	55	53	51	48	31	24	26	
	6.0	360	762	1296	100	65	63	62	59	58	54	38	30	33	62	60	59	57	55	53	34	28	29	
	9.0	540	1143	1944	175	68	67	64	63	61	58	39	31	38	65	63	62	60	58	55	35	27	32	
200x400	3.0	240	508	864	71	60	59	58	56	52	51	34	25	29	58	57	55	53	51	48	30	21	25	
	6.0	480	1016	1728	100	66	65	64	62	60	56	39	31	35	64	62	60	59	57	55	35	28	32	
	9.0	720	1524	2592	175	69	68	67	65	63	61	38	32	38	66	64	62	61	59	56	35	27	32	
250x300	3.0	225	476	810	71	59	58	57	54	50	49	33	26	29	57	55	53	51	48	45	30	23	26	
	6.0	450	953	1620	100	63	62	61	59	56	54	38	31	33	60	58	57	56	54	51	35	28	30	
	9.0	675	1429	2430	175	67	66	64	63	61	58	40	31	39	65	63	62	60	58	55	35	27	32	
250x400	3.0	300	635	1080	71	61	60	59	57	53	52	25	26	30	59	58	56	54	52	50	22	23	28	
	6.0	600	1270	2160	100	64	63	61	58	56	53	37	30	32	62	60	58	57	55	51	33	26	28	
	9.0	900	1906	3240	175	68	66	64	63	61	56	39	31	36	65	63	62	60	58	55	35	27	32	
250x500	3.0	375	794	1350	71	61	58	56	55	52	50	34	26	28	59	57	55	53	52	50	31	23	25	
	6.0	750	1588	2700	100	65	63	62	59	56	54	38	31	33	63	61	59	57	55	53	35	28	30	
	9.0	1125	2382	4050	175	70	68	67	66	65	63	45	38	46	68	66	65	63	61	60	40	33	42	
300x300	3.0	270	572	972	71	61	60	59	57	53	52	25	26	30	59	58	56	54	52	50	22	23	28	
	6.0	540	1143	1944	100	66	65	64	62	60	56	39	31	35	64	62	60	59	57	55	35	28	32	
	9.0	810	1715	2916	175	70	68	67	66	65	63	45	38	46	68	66	65	63	61	60	40	33	42	
300x400	3.0	360	762	1296	71	62	61	59	57	55	52	35	29	31	60	58	56	55	53	50	32	26	28	
	6.0	720	1524	2592	100	68	66	64	63	61	58	39	31	36	65	63	62	60	58	55	35	27	32	
	9.0	1080	2287	3888	175	71	70	68	67	64	61	44	38	47	69	68	66	65	63	61	40	34	41	
300x500	3.0	450	953	1620	71	63	62	61	59	56	54	38	31	33	60	58	57	56	54	51	35	28	30	
	6.0	900	1906	3240	100	68	66	65	62	60	58	36	30	33	64	62	60	59	57	55	35	28	32	
	9.0	1350	2858	4860	175	72	71	70	69	68	67	40	34	41	70	68	67	65	64	62	36	30	37	
300x600	3.0	540	1143	1944	71	63	62	61	58	56	53	37	30	32	62	60	58	57	55	51	33	26	28	
	6.0	1080	2287	3888	100	68	67	66	64	61	59	37	31	36	66	64	62	60	58	56	35	28	32	
	9.0	1620	3430	5832	175	72	71	70	69	68	67	40	34	41	70	68	67	65	64	62	36	30	37	
400x400	3.0	480	1016	1728	71	63	62	60	58	55	53	37	30	32	60	58	57	56	53	50	33	26	28	
	6.0	960	2033	3456	100	68	67	65	63	61	59	39	32	38	66	64	62	61	59	56	35	27	32	
	9.0	1440	3049	5184	175	72	71	70	68	66	65	42	35	43	70	69	68	66	65	63	38	31	39	
400x500	3.0	600	1270	2160	71	64	62	60	58	56	53	37	30	32	62	60	58	56	54	52	33	26	28	
	6.0	1200	2541	4320	100	69	68	67	65	63	61	38	32	38	66	64	62	61	59	56	35	27	32	
	9.0	1800	3811	6480	175	72	71	70	68	66	65	42	35	43	70	69	68	66	65	63	38	31	39	
400x600	3.0	720	1524	2592	71	64	63	61	58	56	53	37	30	32	62	60	58	57	55	51	33	26	28	
	6.0	1440	3049	5184	100	70	68	67	66	65	63	45	38	46	68	66	65	63	61	60	40	33	42	
	9.0	2160	4573	7776	175	73	72	71	70	69	67	44	37	45	71	70	69	68	66	65	40	33	41	
500x500	3.0	750	1588	2700	71	64	63	61	58	56	53	37	30	32	62	60	58	57	55	51	33	26	28	
	6.0	1500	3176	5400	100	70	68	67	66	65	63	45	38	46	68	66	65	63	61	60	40	33	42	
	9.0	2250	4764	8100	175	73	72	71	70	69	67	44	37	45	71	70	69	68	66	65	40	33	41	
500x600	3.0	900	1906	3240	71	65	63	62	59	56	54	38	31	33	63	61	59	57	55	53	35	28	30	
	6.0	1800	3811	6480	100	70	68	67	66	65	63	45	38	46	68	66	65	63	61	60	40	33	42	
	9.0	2700	5717	9720	175	74	73	72	71	70	68	45	38	46	71	70	69	68	66	65	41	33	41	
500x800	3.0	1200	2541	4320	71	66	65	64	62	60	56	39	31	35	64	62	60	59	57	55	35	28	32	
	6.0	2400	5081	8640	100	70	69	68	67	65	63	45	38	47	68	66	65	63	62	61	40	33	43	
	9.0	3600	7622	12960	175	74	73	72	71	70	68	45	38	46	71	70	69	68	66	65	41	33	41	
600x600	3.0	1080	2287	3888	71	67	65	64	63	61	56	39	31	36	6									

