

**KLIMA 2 600**

**Active Chilled Beams**



## Index

Subject	Page
Index	1
Introduction	2
General description	3-4
Product features	5-6
Dimensions	7
Performance data	8-11
Section example	12
Guide specifications	13

## Introduction

The Barcol-Air chilled beam systems are designed to achieve a comfortable indoor climate with low energy consumption and a low ceiling void height. The systems provide cooling, heating, ventilation and humidity control with low noise and minimal maintenance.



Figure 1: KLIMA Active Chilled Beam

## System Technology

Barcol-Air active chilled beams integrate the primary air distribution function with the secondary air heat exchange using a proprietary air nozzle technology to induce secondary room air into the unit and through the heat exchanger before mixing with the primary air. The resulting mixture of primary air and induced secondary room air is then supplied to the room through the contoured diffusers which are designed to keep the air close to the ceiling using the Coanda effect.

Barcol-Air's KLIMA 2 600 series active chilled beams units are designed with a nominal width of 600 mm to integrate with the ceiling grids of the more popular ceiling configurations. Standard unit lengths are nominally 1,200 mm to 3,000 mm in 300 mm increments but special lengths are also available to match with specific ceiling requirements.

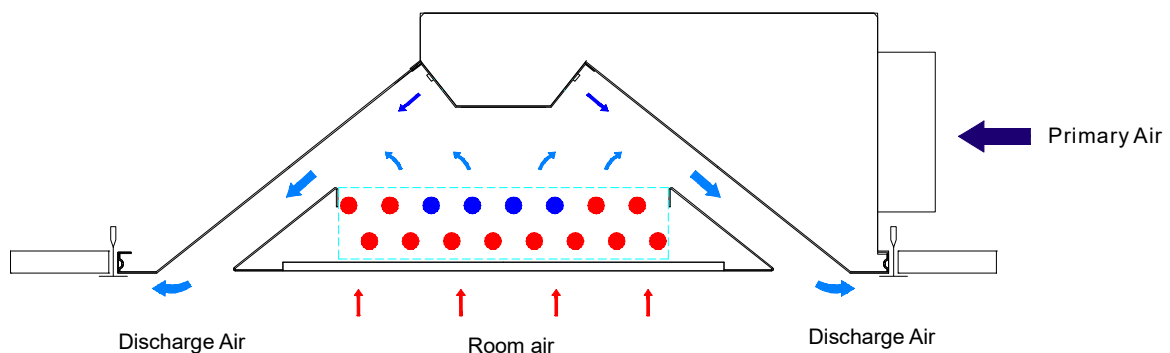

Figure 2: Operating Principle of the Active Chilled Beam

## System Concept

The principle of the active chilled beam system is to use terminal chilled water heat exchangers in the ceiling to offset the room sensible cooling loads or to provide sensible heating. The ventilation and humidity control requirements are taken care of by using separate primary conditioned air supplied by a central air handling unit.

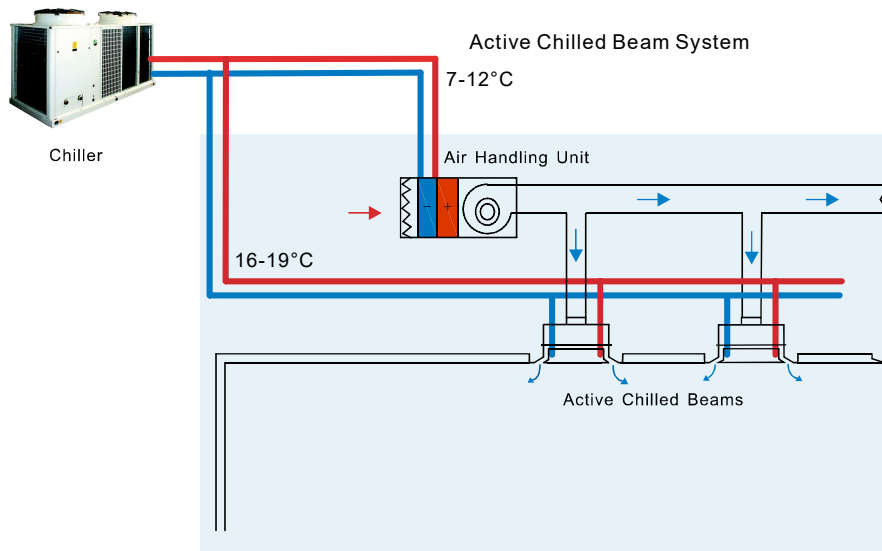

Figure 3: Active Chilled Beam System

Due to the relatively high supply chilled water temperatures, about 16 deg C, the heat exchangers operate dry, avoiding many of the maintenance and health concerns that are associated with other systems that use terminal heat exchangers such as fan coil units.

The system provides large energy savings because the amount of air to be circulated around the building can be reduced to close to that required for ventilation and humidity control only, resulting in large reductions in air handling unit fan power and energy consumption.

Further energy savings result from the use of high chilled water temperatures serving the heat exchangers. This can allow the water chiller to operate at higher water temperatures, giving the opportunity to improve chiller operating efficiency and energy consumption.

## Air distribution

The specific shape of the supply slot diffusers creates two opposing discharge air flows from the active chilled beam along the ceiling. The velocity of the supply air along the ceiling creates the Coanda-effect whereby velocity differences in the cool air stream press the air stream against the ceiling, thereby extending the air throw and preventing the cool air from dropping into the comfort zone prematurely. It is important, with such air patterns, that the ceiling is flat and free of any obstacles, especially light fixtures situated close to the slots, because these can disturb the Coanda-effect.

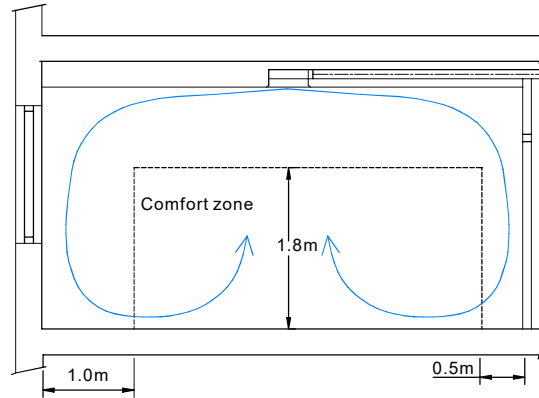

Figure 4: KLIMA – Air Distribution

## Facade-orientation

Orientation of the active chilled beam with regard to the facade has no influence on the operation. There are two common installation arrangements, perpendicular or parallel to the facade. The choice between perpendicular and parallel will be determined by:

- Aesthetics (fitting into the pattern of the ceiling).
- Level of flexibility to create offices within the floor plan.
- Number of active chilled beams required.
- Available distance for the air throw. The air must have the opportunity to mix with the room air before impinging on a wall or an opposing air stream from another chilled beam.
- Disturbances in the suspended ceiling which might influence air pattern, like lighting fixtures.
- Disturbances in the facade or floor, like radiators or floor convectors that could influence the air pattern.

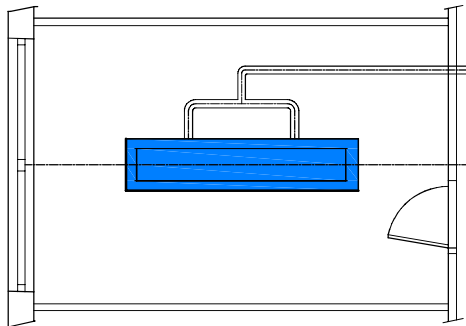

Figure 5: Perpendicular to Facade

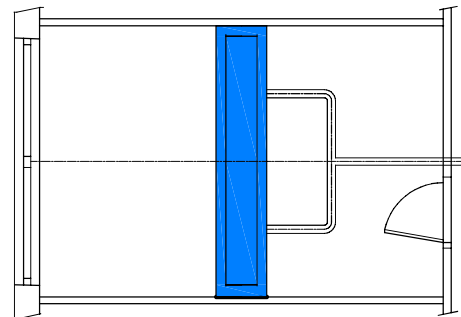

Figure 6: Parallel to Facade

## Product Features

### High capacity with multi choice nozzles

The KLIMA 600 series active chilled beams have a choice of 8 nozzle configurations designed to provide high induction rates for the secondary room air and thereby high cooling and heating capacities. This makes them suitable for application in a building's perimeter zones requiring higher cooling capacities as well as internal zones. Nozzles are factory installed and can be blanked if one side discharge is required.



Figur 7: High Efficiency Air Nozzles

### Low Height:

The KLIMA 600 series has a maximum height of 200 mm allowing the use of reduced height ceiling voids to maximize ceiling heights. Alternatively the building slab to slab height can be reduced allowing more floors in a given building height.

### Flexible Sizes

Units are available with lengths between 1200 mm and 3000 mm to match with most ceiling configurations. Unit lengths can also be tailored to match exact installation requirement.

### Aesthetic Choices

The KLIMA 600 series can be supplied with perforated return air diffusers or linear slot diffusers to match the aesthetic requirements of the building. Exposed metal surfaces are powder painted. The standard finish colour is RAL 9010 with 20% gloss. Other RAL colours can be supplied to match project requirements.

### Simple mounting:

Units can be easily suspended from the concrete slab above using threaded rod or hanging wire support systems to match with metal panel, fiber board or plaster ceilings. Units can also be installed without ceilings.

### Low noise:

The efficiently shaped nozzles create maximum induction with low sound levels.

### Low maintenance:

The KLIMA 600 series active chilled beam has no filter, fan, drain pan or any other moving parts and maintenance is limited to cleaning the exposed metal surfaces and cleaning any dust from the heat exchanger every 2 to 5 years depending on the cleanliness of the supply air. The heat exchanger can be easily accessed by dropping down the centre perforated diffuser which is equipped with a safety hanging wires, and then removing any dust with a vacuum cleaner.

### Controls:

The active chilled beam can be supplied with constant air volume controllers for the primary air, water control valves with room control sensors as well as balancing and isolation valves and condensation sensors.

### Air Distribution Control (Optional)

To allow selection of the air discharge pattern KLIMA 600 series units can be supplied with optional air discharge deflectors. These air deflectors can be independently adjusted to provide different air distribution patterns.

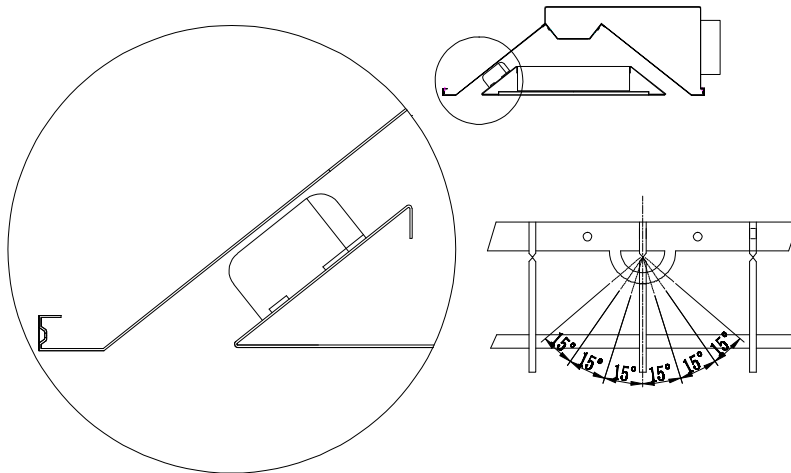
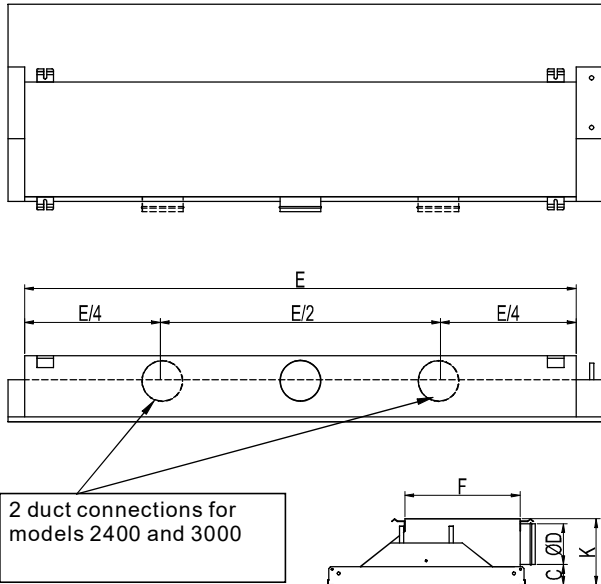

Figure 7 : Air Distribution Control

## Dimension KLIMA 2 600

Duct connection on the side



Duct connection on top

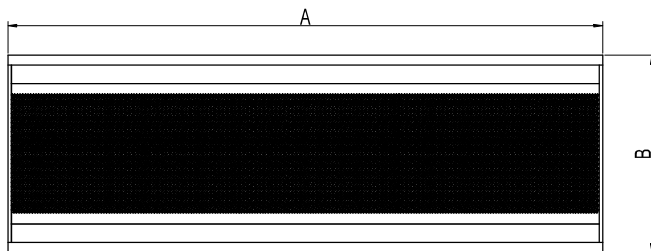
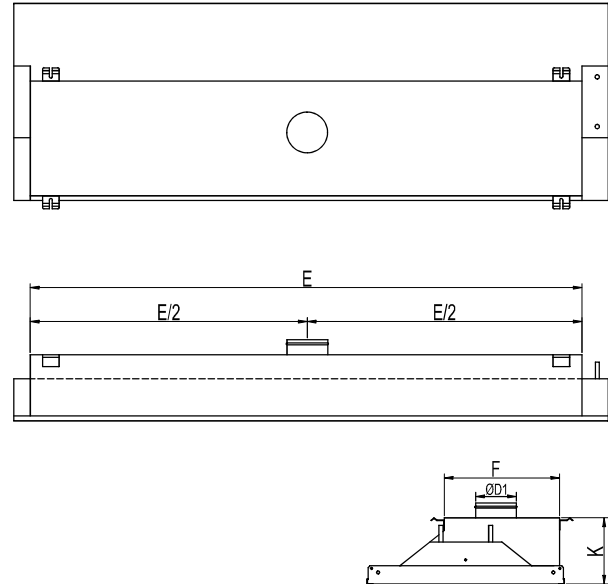

Water Connection Diameters in mm

Unit Size	1200-1800	2400-3000
Chilled water	12	12/15
Hot water	12	12

Table1: Dimensional data KLIMA 600

Size	1200	1500	1800	2400	3000
A	1195	1495	1795	2395	2995
B	595	595	595	595	595
C	62	62	62	62	62
D	1 x $\varnothing 123$	1 x $\varnothing 123$	1 x $\varnothing 123$	2 x $\varnothing 123$	2 x $\varnothing 123$
D1	1 x $\varnothing 123$	1 x $\varnothing 123$	1 x $\varnothing 123$	1 x $\varnothing 158$	1 x $\varnothing 198$
E	1090	1390	1690	2290	2890
F	348	348	348	348	348
K	200	200	200	200	200
Weight (kg) <sup>4</sup>	25	30	34	44	54

1. Dimensions in mm.
2. Air connectors can be provided on the short side of the plenum on request, connector size selected based on airflow.
3. Intermediate lengths are available on request.
4. Plenum internal insulation are available on request.

# Performance Data KLIMA 2 600

KLIMA 600-1200							Cooling Troom minus T entering water temperature = 10 deg C												Heating T entering water temperature minus T room = 35 deg C											
Model	Nozzle	Primary Airflow	Plenum Pressure	Sound Pressure Level	Sound Pressure Level	Air Cooling Capacity ΔT=10°C W	Cooling Water Flow 1				Cooling Water Flow 2				Cooling Water Flow 3				Heating Water Flow 1				Heating Water Flow 2				Heating Water Flow 3			
		L/s	Pa	dBA	NC		Water flow	WaterΔP	Water Cooling Capacity	ΔT Water	Water flow	WaterΔP	Water Cooling Capacity	ΔT Water	Water flow	WaterΔP	Water Cooling Capacity	ΔT Water	Water flow	WaterΔP	Water Heating Capacity	ΔT Water	Water flow	WaterΔP	Water Heating Capacity	ΔT Water	Water flow	WaterΔP	Water Heating Capacity	ΔT Water
1200	A0	6	36	≤15	≤15	73	0.04	4.8	384	2.3	0.06	10.8	440	1.8	0.08	19.2	468	1.4	0.02	0.3	679	8.1	0.03	0.7	859	6.8	0.04	1.2	945	5.6
		8	64	≤15	≤15	97	0.04	4.8	475	2.9	0.06	10.8	545	2.1	0.08	19.2	579	1.7	0.02	0.3	902	10.7	0.03	0.7	1142	9.1	0.04	1.2	1256	7.5
		10	100	≤15	≤15	121	0.04	4.8	546	3.3	0.06	10.8	626	2.5	0.08	19.2	665	2.0	0.02	0.3	1079	12.9	0.03	0.7	1366	10.9	0.04	1.2	1502	9.0
		12	144	18	15	146	0.04	4.8	604	3.6	0.06	10.8	692	2.7	0.08	19.2	736	2.2	0.02	0.3	1225	14.7	0.03	0.7	1551	12.3	0.04	1.2	1706	10.2
		14	196	22	17	170	0.04	4.8	653	3.9	0.06	10.8	749	3.0	0.08	19.2	795	2.4	0.02	0.3	1350	16.1	0.03	0.7	1709	13.6	0.04	1.2	1880	11.2
1200	A1	8	42	≤15	≤15	97	0.04	4.8	415	2.5	0.06	10.8	476	1.9	0.08	19.2	506	1.5	0.02	0.3	846	10.2	0.03	0.7	1071	8.5	0.04	1.2	1178	7.0
		10	66	≤15	≤15	121	0.04	4.8	506	3.0	0.06	10.8	581	2.3	0.08	19.2	617	1.9	0.02	0.3	1021	12.2	0.03	0.7	1292	10.3	0.04	1.2	1422	8.5
		12	95	16	15	146	0.04	4.8	581	3.5	0.06	10.8	666	2.7	0.08	19.2	707	2.1	0.02	0.3	1166	14.0	0.03	0.7	1475	11.8	0.04	1.2	1623	9.7
		14	129	20	15	170	0.04	4.8	643	3.8	0.06	10.8	738	2.9	0.08	19.2	784	2.3	0.02	0.3	1289	15.4	0.03	0.7	1632	13.0	0.04	1.2	1795	10.7
		16	169	23	18	194	0.04	4.8	698	4.2	0.06	10.8	800	3.2	0.08	19.2	850	2.5	0.02	0.3	1397	16.7	0.03	0.7	1768	14.1	0.04	1.2	1945	11.6
1200	B1	12	47	≤15	≤15	146	0.04	4.8	451	2.7	0.06	10.8	517	2.1	0.08	19.2	549	1.6	0.02	0.3	928	11.1	0.03	0.7	1175	9.4	0.04	1.2	1293	7.7
		15	73	17	15	182	0.04	4.8	535	3.2	0.06	10.8	613	2.4	0.08	19.2	652	1.9	0.02	0.3	1075	12.8	0.03	0.7	1360	10.8	0.04	1.2	1496	9.0
		18	105	23	18	218	0.04	4.8	604	3.6	0.06	10.8	692	2.7	0.08	19.2	735	2.2	0.02	0.3	1198	14.3	0.03	0.7	1517	12.1	0.04	1.2	1668	10.0
		21	143	27	22	255	0.04	4.8	662	3.9	0.06	10.8	759	3.0	0.08	19.2	806	2.4	0.02	0.3	1305	15.6	0.03	0.7	1652	13.1	0.04	1.2	1817	10.9
		24	186	31	26	291	0.04	4.8	712	4.2	0.06	10.8	817	3.3	0.08	19.2	868	2.6	0.02	0.3	1400	16.7	0.03	0.7	1772	14.1	0.04	1.2	1949	11.6
1200	C1	18	57	19	≤15	218	0.04	4.8	517	3.1	0.06	10.8	593	2.3	0.08	19.2	630	1.9	0.02	0.3	964	11.5	0.03	0.7	1221	9.7	0.04	1.2	1343	8.0
		22	85	25	20	267	0.04	4.8	585	3.5	0.06	10.8	670	2.7	0.08	19.2	712	2.1	0.02	0.3	1092	13.0	0.03	0.7	1382	11.0	0.04	1.2	1520	9.1
		26	119	30	25	315	0.04	4.8	641	3.8	0.06	10.8	734	2.9	0.08	19.2	780	2.3	0.02	0.3	1201	14.3	0.03	0.7	1521	12.1	0.04	1.2	1673	10.0
		30	158	33	28	364	0.04	4.8	689	4.1	0.06	10.8	790	3.1	0.08	19.2	839	2.5	0.02	0.3	1297	15.5	0.03	0.7	1642	13.1	0.04	1.2	1807	10.8
		34	203	36	31	412	0.04	4.8	731	4.4	0.06	10.8	838	3.3	0.08	19.2	890	2.7	0.02	0.3	1383	16.5	0.03	0.7	1750	13.9	0.04	1.2	1926	11.5
1200	E1	24	58	25	20	291	0.04	4.8	556	3.3	0.06	10.8	638	2.5	0.08	19.2	677	2.0	0.02	0.3	1067	12.8	0.03	0.7	1350	10.7	0.04	1.2	1485	8.9
		28	79	29	24	340	0.04	4.8	607	3.6	0.06	10.8	696	2.8	0.08	19.2	739	2.2	0.02	0.3	1166	14.0	0.03	0.7	1476	11.8	0.04	1.2	1624	9.7
		32	103	33	28	388	0.04	4.8	651	3.9	0.06	10.8	746	3.0	0.08	19.2	793	2.4	0.02	0.3	1253	14.9	0.03	0.7	1586	12.7	0.04	1.2	1744	10.4
		36	130	36	31	437	0.04	4.8	690	4.1	0.06	10.8	791	3.1	0.08	19.2	840	2.5	0.02	0.3	1330	15.9	0.03	0.7	1683	13.4	0.04	1.2	1852	11.0
		40	160	38	33	485	0.04	4.8	724	4.3	0.06	10.8	830	3.3	0.08	19.2	882	2.6	0.02	0.3	1399	16.7	0.03	0.7	1771	14.1	0.04	1.2	1948	11.6
1200	F1	28	50	27	22	340	0.04	4.8	558	3.3	0.06	10.8	640	2.5	0.08	19.2	680	2.0	0.02	0.3	1073	12.8	0.03	0.7	1358	10.8	0.04	1.2	1493	8.9
		33	70	32	27	400	0.04	4.8	608	3.6	0.06	10.8	697	2.8	0.08	19.2	741	2.2	0.02	0.3	1173	14.0	0.03	0.7	1485	11.8	0.04	1.2	1633	9.7
		38	93	35	30	461	0.04	4.8	651	3.9	0.06	10.8	747	3.0	0.08	19.2	793	2.4	0.02	0.3	1259	15.0	0.03	0.7	1594	12.7	0.04	1.2	1753	10.4
		43	119	39	34	522	0.04	4.8	689	4.1	0.06	10.8	790	3.1	0.08	19.2	839	2.5	0.02	0.3	1334	15.9	0.03	0.7	1689	13.5	0.04	1.2	1858	11.1
		48	148	42	37	582	0.04	4.8	723	4.3	0.06	10.8	829	3.3	0.08	19.2	880	2.6	0.02	0.3	1401	16.7	0.03	0.7	1774	14.1	0.04	1.2	1951	11.6
1200	G1	32	52	30	25	388	0.04	4.8	562	3.3	0.06	10.8	644	2.5	0.08	19.2	685	2.0	0.02	0.3	1103	13.1	0.03	0.7	1397	11.1	0.04	1.2	1536	9.2
		38	73	35	30	461	0.04	4.8	616	3.7	0.06	10.8	707	2.8	0.08	19.2	751	2.2	0.02	0.3	1183	14.1	0.03	0.7	1497	11.9	0.04	1.2	1647	9.9
		44	97	39	34	534	0.04	4.8	663	3.9	0.06	10.8	760	3.0	0.08	19.2	808	2.4	0.02	0.3	1253	14.9	0.03	0.7	1586	12.7	0.04	1.2	1744	10.4
		50	126	43	38	607	0.04	4.8	704	4.2	0.06	10.8	807	3.2	0.08	19.2	857	2.6	0.02	0.3	1315	15.8	0.03	0.7	1665	13.2	0.04	1.2	1831	10.9
		56	158	46	41	679	0.04	4.8	740	4.4	0.06	10.8	848	3.4	0.08	19.2	901	2.7	0.02	0.3	1371	16.4	0.03	0.7	1736	13.9	0.04	1.2	1910	11.4
1200	H1	44	47	36	31	534	0.04	4.8	641	3.8	0.06	10.8	735	2.9	0.08	19.2	781	2.3	0.02	0.3	1166	14.0	0.03	0.7	1476	11.8	0.04	1.2	1623	9.7
		52	66	42	37	631	0.04	4.8	676	4.1	0.06	10.8	776	3.1	0.08	19.2	824	2.4	0.02	0.3	1238	14.8	0.03	0.7	1567	12.5	0.04	1.2	1723	10.3
		60	88	46	41	728	0.04	4.8	707	4.2	0.06	10.8	810	3.2	0.08	19.2	861	2.6	0.02	0.3	1300	15.5	0.03	0.7	1646	13.1	0.04	1.2	1810	10.8
		68	113	48	43	825	0.04	4.8	733	4.4	0.06	10.8	841	3.3	0.08	19.2	894	2.7	0.02	0.3	1355	16.1	0.03	0.7	1715	13.6	0.04	1.2	1886	11.3
		76	142	51	46	922	0.04	4.8	757	4.5	0.06	10.8	868	3.5	0.08	19.2	922	2.7	0.02	0.3	1404	16.7	0.03	0.7	1777	14.2	0.04	1.2	1955	11.6

**Performance table notes**

1) Air cooling capacities are based on Troom minus T primary air = 10 deg C. For other conditions multiply the table air cooling capacity by the required (Troom minus Tprimary air) divided by 10.

Alternatively the air cooling capacity can be calculated from the formula: Air cooling capacity W = 1.213 x Airflow (l/s) x (Troom minus T primary air)

2) Water cooling capacities are based on 2 pipe chilled beams with Troom minus T entering water temperature = 10 deg C. For other conditions multiply the table water cooling capacity by the required (Troom minus T entering water) divided by 10.

3) Water heating capacities are based on 4 pipe chilled beams with T room minus T entering water temperature = 35 deg C. For other conditions multiply the table water heating capacity by the required (Troom minus T entering water) divided by 35.

# Performance Data KLIMA 2 600

KLIMA 600-1800							Cooling Troom minus T entering water temperature = 10 deg C												Heating T entering water temperature minus T room = 35 deg C											
Model	Nozzle	Primary Airflow	Plenum Pressure	Sound Pressure Level	Sound Pressure Level	Air Cooling Capacity ΔT=10°C W	Cooling Water Flow 1				Cooling Water Flow 2				Cooling Water Flow 3				Heating Water Flow 1				Heating Water Flow 2				Heating Water Flow 3			
		L/s	Pa	dBA	NC		Water flow	WaterΔP	Water Cooling Capacity	ΔT Water	Water flow	WaterΔP	Water Cooling Capacity	ΔT Water	Water flow	WaterΔP	Water Cooling Capacity	ΔT Water	Water flow	WaterΔP	Water Heating Capacity	ΔT Water	Water flow	WaterΔP	Water Heating Capacity	ΔT Water	Water flow	WaterΔP	Water Heating Capacity	ΔT Water
1800	A0	10	40	≤15	≤15	121	0.04	5.8	585	3.5	0.06	13.1	670	2.7	0.08	23.3	712	2.1	0.03	0.9	1070	8.5	0.04	1.5	1354	8.1	0.05	2.4	1490	7.1
		13	68	≤15	≤15	158	0.04	5.8	706	4.2	0.06	13.1	809	3.2	0.08	23.3	860	2.6	0.03	0.9	1422	11.3	0.04	1.5	1800	10.7	0.05	2.4	1980	9.5
		16	103	20	≤15	194	0.04	5.8	802	4.8	0.06	13.1	919	3.7	0.08	23.3	977	2.9	0.03	0.9	1701	13.5	0.04	1.5	2153	12.8	0.05	2.4	2369	11.3
		19	145	26	21	230	0.04	5.8	881	5.3	0.06	13.1	1011	4.0	0.08	23.3	1074	3.2	0.03	0.9	1932	15.4	0.04	1.5	2446	14.6	0.05	2.4	2690	12.8
		22	195	29	24	267	0.04	5.8	949	5.7	0.06	13.1	1088	4.3	0.08	23.3	1156	3.5	0.03	0.9	2129	17.0	0.04	1.5	2695	16.1	0.05	2.4	2964	14.1
1800	A1	13	45	≤15	≤15	158	0.04	5.8	623	3.7	0.06	13.1	714	2.8	0.08	23.3	759	2.3	0.03	0.9	1334	10.6	0.04	1.5	1689	10.1	0.05	2.4	1858	8.9
		16	68	18	≤15	194	0.04	5.8	746	4.5	0.06	13.1	855	3.4	0.08	23.3	909	2.7	0.03	0.9	1610	12.8	0.04	1.5	2038	12.2	0.05	2.4	2242	10.7
		19	96	23	18	230	0.04	5.8	848	5.1	0.06	13.1	972	3.9	0.08	23.3	1033	3.1	0.03	0.9	1838	14.6	0.04	1.5	2327	13.9	0.05	2.4	2559	12.2
		22	129	27	22	267	0.04	5.8	935	5.6	0.06	13.1	1072	4.3	0.08	23.3	1139	3.4	0.03	0.9	2033	16.2	0.04	1.5	2573	15.3	0.05	2.4	2830	13.5
		25	166	31	26	303	0.04	5.8	1011	6.0	0.06	13.1	1159	4.6	0.08	23.3	1231	3.7	0.03	0.9	2202	17.5	0.04	1.5	2788	16.7	0.05	2.4	3066	14.7
1800	B1	20	52	21	16	243	0.04	5.8	687	4.1	0.06	13.1	787	3.1	0.08	23.3	837	2.5	0.03	0.9	1464	11.6	0.04	1.5	1853	11.0	0.05	2.4	2038	9.7
		24	75	26	21	291	0.04	5.8	787	4.7	0.06	13.1	902	3.6	0.08	23.3	959	2.9	0.03	0.9	1694	13.5	0.04	1.5	2145	12.8	0.05	2.4	2359	11.3
		28	102	30	25	340	0.04	5.8	872	5.2	0.06	13.1	999	4.0	0.08	23.3	1062	3.2	0.03	0.9	1889	15.0	0.04	1.5	2392	14.3	0.05	2.4	2631	12.6
		32	133	34	29	388	0.04	5.8	945	5.6	0.06	13.1	1083	4.3	0.08	23.3	1151	3.4	0.03	0.9	2058	16.4	0.04	1.5	2605	15.6	0.05	2.4	2866	13.7
		36	168	37	32	437	0.04	5.8	1010	6.0	0.06	13.1	1158	4.6	0.08	23.3	1230	3.7	0.03	0.9	2207	17.6	0.04	1.5	2794	16.7	0.05	2.4	3073	14.7
1800	C1	28	55	28	23	340	0.04	5.8	747	4.5	0.06	13.1	856	3.4	0.08	23.3	910	2.7	0.03	0.9	1521	12.1	0.04	1.5	1925	11.5	0.05	2.4	2117	10.1
		33	77	32	27	400	0.04	5.8	827	5.0	0.06	13.1	948	3.8	0.08	23.3	1007	3.0	0.03	0.9	1722	13.7	0.04	1.5	2180	13.0	0.05	2.4	2398	11.5
		38	102	36	31	461	0.04	5.8	896	5.4	0.06	13.1	1027	4.1	0.08	23.3	1091	3.3	0.03	0.9	1895	15.0	0.04	1.5	2398	14.3	0.05	2.4	2638	12.6
		43	131	39	34	522	0.04	5.8	956	5.7	0.06	13.1	1096	4.4	0.08	23.3	1165	3.5	0.03	0.9	2046	16.3	0.04	1.5	2590	15.5	0.05	2.4	2849	13.6
		48	163	41	36	582	0.04	5.8	1010	6.0	0.06	13.1	1158	4.6	0.08	23.3	1230	3.7	0.03	0.9	2181	17.4	0.04	1.5	2760	16.5	0.05	2.4	3036	14.5
1800	E1	38	58	34	29	461	0.04	5.8	812	4.8	0.06	13.1	931	3.7	0.08	23.3	989	3.0	0.03	0.9	1682	13.4	0.04	1.5	2129	12.7	0.05	2.4	2342	11.2
		44	78	38	33	534	0.04	5.8	882	5.3	0.06	13.1	1011	4.0	0.08	23.3	1075	3.2	0.03	0.9	1839	14.6	0.04	1.5	2328	13.9	0.05	2.4	2560	12.2
		50	101	40	35	607	0.04	5.8	943	5.6	0.06	13.1	1082	4.3	0.08	23.3	1149	3.4	0.03	0.9	1976	15.8	0.04	1.5	2501	14.9	0.05	2.4	2751	13.1
		56	126	44	39	679	0.04	5.8	998	6.0	0.06	13.1	1144	4.5	0.08	23.3	1215	3.6	0.03	0.9	2097	16.7	0.04	1.5	2654	15.8	0.05	2.4	2920	13.9
		62	155	47	42	752	0.04	5.8	1047	6.3	0.06	13.1	1200	4.8	0.08	23.3	1275	3.8	0.03	0.9	2206	17.6	0.04	1.5	2792	16.7	0.05	2.4	3071	14.7
1800	F1	44	50	36	31	534	0.04	5.8	811	4.8	0.06	13.1	930	3.7	0.08	23.3	988	3.0	0.03	0.9	1691	13.5	0.04	1.5	2141	12.8	0.05	2.4	2355	11.3
		52	69	40	35	631	0.04	5.8	885	5.3	0.06	13.1	1015	4.1	0.08	23.3	1079	3.2	0.03	0.9	1850	14.7	0.04	1.5	2341	14.0	0.05	2.4	2576	12.3
		60	93	44	39	728	0.04	5.8	949	5.7	0.06	13.1	1088	4.3	0.08	23.3	1156	3.5	0.03	0.9	1985	15.8	0.04	1.5	2513	15.0	0.05	2.4	2765	13.2
		68	119	47	42	825	0.04	5.8	1005	6.0	0.06	13.1	1152	4.6	0.08	23.3	1224	3.6	0.03	0.9	2104	16.7	0.04	1.5	2663	15.9	0.05	2.4	2930	14.0
		76	148	50	45	922	0.04	5.8	1054	6.3	0.06	13.1	1209	4.8	0.08	23.3	1284	3.8	0.03	0.9	2210	17.6	0.04	1.5	2797	16.7	0.05	2.4	3077	14.7
1800	G1	54	59	40	35	655	0.04	5.8	850	5.1	0.06	13.1	974	3.9	0.08	23.3	1035	3.1	0.03	0.9	1740	13.9	0.04	1.5	2202	13.1	0.05	2.4	2423	11.6
		62	77	44	39	752	0.04	5.8	914	5.4	0.06	13.1	1047	4.2	0.08	23.3	1113	3.3	0.03	0.9	1865	14.9	0.04	1.5	2361	14.1	0.05	2.4	2597	12.4
		70	98	47	42	849	0.04	5.8	970	5.8	0.06	13.1	1112	4.4	0.08	23.3	1181	3.5	0.03	0.9	1976	15.8	0.04	1.5	2501	14.9	0.05	2.4	2751	13.1
		78	122	49	44	946	0.04	5.8	1020	6.1	0.06	13.1	1169	4.7	0.08	23.3	1242	3.7	0.03	0.9	2074	16.5	0.04	1.5	2625	15.7	0.05	2.4	2888	13.8
		86	149	51	46	1043	0.04	5.8	1065	6.3	0.06	13.1	1221	4.9	0.08	23.3	1297	3.9	0.03	0.9	2163	17.2	0.04	1.5	2737	16.4	0.05	2.4	3011	14.4
1800	H1	72	51	46	41	873	0.04	5.8	945	5.6	0.06	13.1	1083	4.3	0.08	23.3	1151	3.4	0.03	0.9	1839	14.6	0.04	1.5	2327	13.9	0.05	2.4	2560	12.2
		84	69	48	43	1019	0.04	5.8	992	5.9	0.06	13.1	1138	4.5	0.08	23.3	1209	3.6	0.03	0.9	1952	15.5	0.04	1.5	2471	14.7	0.05	2.4	2718	13.0
		96	90	51	46	1164	0.04	5.8	1034	6.1	0.06	13.1	1185	4.7	0.08	23.3	1259	3.8	0.03	0.9	2050	16.3	0.04	1.5	2595	15.5	0.05	2.4	2854	13.6
		108	114	53	48	1310	0.04	5.8	1070	6.4	0.06	13.1	1227	4.9	0.08	23.3	1304	3.9	0.03	0.9	2136	17.0	0.04	1.5	2704	16.1	0.05	2.4	2975	14.2
		120	141	56	51	1456	0.04	5.8	1103	6.6	0.06	13.1	1265	5.0	0.08	23.3	1344	4.0	0.03	0.9	2214	17.6	0.04	1.5	2802	16.7	0.05	2.4	3083	14.7

**Performance table notes**

- Air cooling capacities are based on Troom minus T primary air = 10 deg C. For other conditions multiply the table air cooling capacity by the required (Troom minus Tprimary air) divided by 10. Alternatively the air cooling capacity can be calculated from the formula: Air cooling capacity W = 1.213 x Airflow (l/s) x (Troom minus T primary air)
- Water cooling capacities are based on 2 pipe chilled beams with Troom minus T entering water temperature = 10 deg C. For other conditions multiply the table water cooling capacity by the required (Troom minus T entering water) divided by 10.
- Water heating capacities are based on 4 pip chilled beams with T room minus T entering water temperature = 35 deg C. For other conditions multiply the table water heating capacity by the required (Troom minus T entering water) divided by 35.

# Performance Data KLIMA 2 600

KLIMA 600-2400							Cooling Troom minus T entering water temperature = 10 deg C												Heating T entering water temperature minus T room = 35 deg C											
Model	Nozzle	Primary Airflow	Plenum Pressure	Sound Pressure Level	Sound Pressure Level	Air Cooling Capacity ΔT=10°C	Cooling Water Flow 1				Cooling Water Flow 2				Cooling Water Flow 3				Heating Water Flow 1				Heating Water Flow 2				Heating Water Flow 3			
		L/s	Pa	dBA	NC	W	Water flow	Water ΔP	Water Cooling Capacity	ΔT Water	Water flow	Water ΔP	Water Cooling Capacity	ΔT Water	Water flow	Water ΔP	Water Cooling Capacity	ΔT Water	Water flow	Water ΔP	Water Heating Capacity	ΔT Water	Water flow	Water ΔP	Water Heating Capacity	ΔT Water	Water flow	Water ΔP	Water Heating Capacity	ΔT Water
2400	A0	14	43	≤15	≤15	170	0.06	3.2	842	3.3	0.09	7.1	957	2.5	0.12	12.7	998	2.0	0.04	1.9	1461	8.7	0.05	2.9	1850	8.8	0.06	4.2	2035	8.1
		18	70	16	≤15	218	0.06	3.2	1007	4.0	0.09	7.1	1144	3.0	0.12	12.7	1193	2.4	0.04	1.9	1943	11.6	0.05	2.9	2459	11.8	0.06	4.2	2705	10.8
		22	105	21	16	267	0.06	3.2	1138	4.5	0.09	7.1	1292	3.4	0.12	12.7	1348	2.7	0.04	1.9	2324	13.9	0.05	2.9	2941	14.0	0.06	4.2	3235	12.9
		26	147	25	20	315	0.06	3.2	1247	5.0	0.09	7.1	1416	3.8	0.12	12.7	1477	2.9	0.04	1.9	2639	15.8	0.05	2.9	3340	16.0	0.06	4.2	3674	14.6
		30	196	29	24	364	0.06	3.2	1340	5.3	0.09	7.1	1523	4.0	0.12	12.7	1588	3.2	0.04	1.9	2908	17.4	0.05	2.9	3681	17.6	0.06	4.2	4049	16.1
2400	A1	19	51	≤15	≤15	230	0.06	3.2	937	3.7	0.09	7.1	1064	2.8	0.12	12.7	1110	2.2	0.04	1.9	1823	10.9	0.05	2.9	2307	11.0	0.06	4.2	2538	10.1
		23	75	20	≤15	279	0.06	3.2	1097	4.4	0.09	7.1	1246	3.3	0.12	12.7	1300	2.6	0.04	1.9	2199	13.1	0.05	2.9	2784	13.3	0.06	4.2	3062	12.2
		27	104	25	20	328	0.06	3.2	1232	4.9	0.09	7.1	1399	3.7	0.12	12.7	1459	2.9	0.04	1.9	2511	15.0	0.05	2.9	3178	15.2	0.06	4.2	3496	13.9
		31	137	28	23	376	0.06	3.2	1347	5.4	0.09	7.1	1531	4.1	0.12	12.7	1596	3.2	0.04	1.9	2776	16.6	0.05	2.9	3514	16.8	0.06	4.2	3866	15.4
		35	174	32	27	425	0.06	3.2	1449	5.8	0.09	7.1	1646	4.4	0.12	12.7	1717	3.4	0.04	1.9	3008	18.0	0.05	2.9	3808	18.2	0.06	4.2	4188	16.7
2400	B1	28	55	22	17	340	0.06	3.2	990	3.9	0.09	7.1	1124	3.0	0.12	12.7	1173	2.3	0.04	1.9	2000	11.9	0.05	2.9	2531	12.1	0.06	4.2	2784	11.1
		33	76	26	21	400	0.06	3.2	1117	4.5	0.09	7.1	1269	3.4	0.12	12.7	1324	2.6	0.04	1.9	2314	13.8	0.05	2.9	2930	14.0	0.06	4.2	3223	12.8
		38	101	30	25	461	0.06	3.2	1227	4.9	0.09	7.1	1394	3.7	0.12	12.7	1454	2.9	0.04	1.9	2581	15.4	0.05	2.9	3266	15.6	0.06	4.2	3496	14.3
		43	129	33	28	522	0.06	3.2	1323	5.3	0.09	7.1	1503	4.0	0.12	12.7	1567	3.1	0.04	1.9	2811	16.8	0.05	2.9	3558	17.0	0.06	4.2	3914	15.6
		48	161	36	31	582	0.06	3.2	1408	5.6	0.09	7.1	1600	4.2	0.12	12.7	1669	3.3	0.04	1.9	3014	18.0	0.05	2.9	3816	18.2	0.06	4.2	4197	16.7
2400	C1	37	52	27	22	449	0.06	3.2	1032	4.1	0.09	7.1	1173	3.1	0.12	12.7	1223	2.4	0.04	1.9	2077	12.4	0.05	2.9	2629	12.6	0.06	4.2	2892	11.5
		44	73	32	27	534	0.06	3.2	1152	4.6	0.09	7.1	1309	3.5	0.12	12.7	1365	2.7	0.04	1.9	2352	14.0	0.05	2.9	2977	14.2	0.06	4.2	3275	13.0
		51	99	35	30	619	0.06	3.2	1254	5.0	0.09	7.1	1424	3.8	0.12	12.7	1486	3.0	0.04	1.9	2588	15.5	0.05	2.9	3276	15.7	0.06	4.2	3603	14.3
		58	127	39	34	704	0.06	3.2	1343	5.3	0.09	7.1	1525	4.1	0.12	12.7	1591	3.2	0.04	1.9	2795	16.7	0.05	2.9	3537	16.9	0.06	4.2	3891	15.5
		65	160	42	37	788	0.06	3.2	1421	5.7	0.09	7.1	1615	4.3	0.12	12.7	1684	3.3	0.04	1.9	2978	17.8	0.05	2.9	3770	18.0	0.06	4.2	4147	16.5
2400	E1	48	50	31	26	582	0.06	3.2	1094	4.3	0.09	7.1	1243	3.3	0.12	12.7	1296	2.6	0.04	1.9	2297	13.7	0.05	2.9	2908	13.9	0.06	4.2	3199	12.7
		58	72	36	31	704	0.06	3.2	1222	4.9	0.09	7.1	1389	3.7	0.12	12.7	1448	2.9	0.04	1.9	2512	15.0	0.05	2.9	3179	15.2	0.06	4.2	3497	13.9
		68	99	40	35	825	0.06	3.2	1330	5.3	0.09	7.1	1511	4.0	0.12	12.7	1576	3.1	0.04	1.9	2698	16.1	0.05	2.9	3416	16.3	0.06	4.2	3757	15.0
		78	131	44	39	946	0.06	3.2	1423	5.7	0.09	7.1	1617	4.3	0.12	12.7	1686	3.4	0.04	1.9	2864	17.1	0.05	2.9	3625	17.3	0.06	4.2	3988	15.9
		88	166	47	42	1067	0.06	3.2	1505	6.0	0.09	7.1	1710	4.5	0.12	12.7	1783	3.5	0.04	1.9	3013	18.0	0.05	2.9	3814	18.2	0.06	4.2	4195	16.7
2400	F1	60	50	35	30	728	0.06	3.2	1145	4.6	0.09	7.1	1301	3.4	0.12	12.7	1357	2.7	0.04	1.9	2310	13.8	0.05	2.9	2924	13.9	0.06	4.2	3217	12.8
		72	72	40	35	873	0.06	3.2	1260	5.0	0.09	7.1	1431	3.8	0.12	12.7	1493	3.0	0.04	1.9	2527	15.1	0.05	2.9	3198	15.3	0.06	4.2	3518	14.0
		84	97	44	39	1019	0.06	3.2	1357	5.4	0.09	7.1	1541	4.1	0.12	12.7	1608	3.2	0.04	1.9	2712	16.2	0.05	2.9	3433	16.4	0.06	4.2	3776	15.0
		96	127	47	42	1164	0.06	3.2	1441	5.7	0.09	7.1	1637	4.4	0.12	12.7	1707	3.4	0.04	1.9	2874	17.1	0.05	2.9	3638	17.4	0.06	4.2	4002	15.9
		108	161	51	46	1310	0.06	3.2	1515	6.0	0.09	7.1	1721	4.6	0.12	12.7	1795	3.6	0.04	1.9	3018	18.0	0.05	2.9	3820	18.2	0.06	4.2	4202	16.7
2400	G1	70	53	39	34	849	0.06	3.2	1167	4.7	0.09	7.1	1325	3.5	0.12	12.7	1382	2.7	0.04	1.9	2376	14.2	0.05	2.9	3008	14.4	0.06	4.2	3309	13.2
		82	73	43	38	995	0.06	3.2	1270	5.1	0.09	7.1	1443	3.8	0.12	12.7	1505	3.0	0.04	1.9	2548	15.2	0.05	2.9	3225	15.4	0.06	4.2	3548	14.1
		94	95	46	41	1140	0.06	3.2	1359	5.4	0.09	7.1	1544	4.1	0.12	12.7	1610	3.2	0.04	1.9	2698	16.1	0.05	2.9	3416	16.3	0.06	4.2	3757	15.0
		106	121	49	44	1286	0.06	3.2	1438	5.7	0.09	7.1	1633	4.3	0.12	12.7	1703	3.4	0.04	1.9	2833	16.9	0.05	2.9	3586	17.1	0.06	4.2	3944	15.7
		118	150	52	47	1431	0.06	3.2	1508	6.0	0.09	7.1	1713	4.5	0.12	12.7	1786	3.6	0.04	1.9	2954	17.6	0.05	2.9	3739	17.9	0.06	4.2	4113	16.4
2400	H1	90	43	42	37	1092	0.06	3.2	1296	5.2	0.09	7.1	1473	3.9	0.12	12.7	1536	3.1	0.04	1.9	2511	15.0	0.05	2.9	3179	15.2	0.06	4.2	3497	13.9
		110	64	47	42	1334	0.06	3.2	1384	5.5	0.09	7.1	1572	4.2	0.12	12.7	1640	3.3	0.04	1.9	2666	15.9	0.05	2.9	3375	16.1	0.06	4.2	3712	14.8
		130	90	51	46	1577	0.06	3.2	1457	5.8	0.09	7.1	1656	4.4	0.12	12.7	1727	3.4	0.04	1.9	2800	16.7	0.05	2.9	3544	16.9	0.06	4.2	3899	15.5
		150	119	55	50	1820	0.06	3.2	1520	6.1	0.09	7.1	1727	4.6	0.12	12.7	1801	3.6	0.04	1.9	2918	17.4	0.05	2.9	3694	17.6	0.06	4.2	4063	16.2
		170	153	60	55	2062	0.06	3.2	1575	6.2	0.09	7.1	1789	4.8	0.12	12.7	1866	3.7	0.04	1.9	3024	18.0	0.05	2.9	3828	18.3	0.06	4.2	4210	16.8

**Performance table notes**

- Air cooling capacities are based on Troom minus T primary air = 10 deg C. For other conditions multiply the table air cooling capacity by the required (Troom minus Tprimary air) divided by 10. Alternatively the air cooling capacity can be calculated from the formula: Air cooling capacity W = 1.213 x Airflow (l/s) x (Troom minus T primary air)
- Water cooling capacities are based on 2 pipe chilled beams with Troom minus T entering water temperature = 10 deg C. For other conditions multiply the table water cooling capacity by the required (Troom minus T entering water) divided by 10.
- Water heating capacities are based on 4 pipe chilled beams with T room minus T entering water temperature = 35 deg C. For other conditions multiply the table water heating capacity by the required (Troom minus T entering water) divided by 35.

# Performance Data KLIMA 2 600

KLIMA 600-3000							Cooling Troom minus T entering water temperature = 10 deg C												Heating T entering water temperature minus T room = 35 deg C											
Model	Nozzle	Primary Airflow	Plenum Pressure	Sound Pressure Level	Sound Pressure Level	Air Cooling Capacity ΔT=10C W	Cooling Water Flow 1				Cooling Water Flow 2				Cooling Water Flow 3				Heating Water Flow 1				Heating Water Flow 2				Heating Water Flow 3			
		L/s	Pa	dBA	NC		Water flow	WaterΔP	Water Cooling Capacity	ΔT Water	Water flow	WaterΔP	Water Cooling Capacity	ΔT Water	Water flow	WaterΔP	Water Cooling Capacity	ΔT Water	Water flow	WaterΔP	Water Heating Capacity	ΔT Water	Water flow	WaterΔP	Water Heating Capacity	ΔT Water	Water flow	WaterΔP	Water Heating Capacity	ΔT Water
3000	A0	17	39	16	≤15	206	0.06	3.5	946	3.8	0.09	7.8	1094	2.9	0.12	13.9	1186	2.4	0.04	2.2	1853	10.8	0.05	3.4	2299	11.0	0.06	4.9	2580	10.3
		22	65	18	≤15	267	0.06	3.5	1142	4.5	0.09	7.8	1321	3.5	0.12	13.9	1432	2.8	0.04	2.2	2463	14.4	0.05	3.4	3055	14.7	0.06	4.9	3430	13.7
		27	98	24	19	328	0.06	3.5	1297	5.2	0.09	7.8	1500	4.0	0.12	13.9	1627	3.2	0.04	2.2	2946	17.2	0.05	3.4	3654	17.6	0.06	4.9	4102	16.3
		32	138	29	24	388	0.06	3.5	1426	5.7	0.09	7.8	1649	4.4	0.12	13.9	1789	3.6	0.04	2.2	3346	19.6	0.05	3.4	4150	20.0	0.06	4.9	4658	18.5
		37	185	33	28	449	0.06	3.5	1536	6.1	0.09	7.8	1777	4.7	0.12	13.9	1927	3.8	0.04	2.2	3687	21.6	0.05	3.4	4573	22.0	0.06	4.9	5133	20.4
3000	A1	24	51	18	≤15	291	0.06	3.5	1085	4.3	0.09	7.8	1255	3.3	0.12	13.9	1361	2.7	0.04	2.2	2311	13.5	0.05	3.4	2852	13.8	0.06	4.9	3218	12.8
		29	75	24	19	352	0.06	3.5	1269	5.1	0.09	7.8	1468	3.9	0.12	13.9	1592	3.2	0.04	2.2	2788	16.2	0.05	3.4	3441	16.7	0.06	4.9	3882	15.4
		34	102	28	23	412	0.06	3.5	1424	5.7	0.09	7.8	1647	4.4	0.12	13.9	1786	3.6	0.04	2.2	3183	18.5	0.05	3.4	3928	19.0	0.06	4.9	4432	17.6
		39	135	32	27	473	0.06	3.5	1558	6.2	0.09	7.8	1802	4.8	0.12	13.9	1954	3.9	0.04	2.2	3520	20.5	0.05	3.4	4344	21.0	0.06	4.9	4901	19.5
		44	172	35	30	534	0.06	3.5	1675	6.7	0.09	7.8	1938	5.1	0.12	13.9	2101	4.2	0.04	2.2	3814	22.2	0.05	3.4	4707	22.7	0.06	4.9	5310	21.1
3000	B1	34	50	25	20	412	0.06	3.5	1111	4.4	0.09	7.8	1285	3.4	0.12	13.9	1393	2.8	0.04	2.2	2535	15.4	0.05	3.4	3267	15.2	0.06	4.9	3530	14.1
		41	73	30	25	497	0.06	3.5	1280	5.1	0.09	7.8	1480	3.9	0.12	13.9	1605	3.2	0.04	2.2	2934	17.4	0.05	3.4	3699	17.8	0.06	4.9	4086	16.3
		48	100	34	29	582	0.06	3.5	1422	5.7	0.09	7.8	1645	4.4	0.12	13.9	1783	3.5	0.04	2.2	3272	19.2	0.05	3.4	4070	19.5	0.06	4.9	4556	18.2
		55	131	37	32	667	0.06	3.5	1545	6.1	0.09	7.8	1787	4.8	0.12	13.9	1937	3.9	0.04	2.2	3564	20.7	0.05	3.4	4395	21.3	0.06	4.9	4963	19.7
		62	167	41	36	752	0.06	3.5	1653	6.6	0.09	7.8	1912	5.1	0.12	13.9	2073	4.1	0.04	2.2	3822	22.1	0.05	3.4	4685	22.8	0.06	4.9	5322	21.2
3000	C1	50	59	33	28	607	0.06	3.5	1250	5.0	0.09	7.8	1446	3.8	0.12	13.9	1568	3.1	0.04	2.2	2633	17.2	0.05	3.4	3650	15.7	0.06	4.9	3667	14.6
		58	79	36	31	704	0.06	3.5	1369	5.5	0.09	7.8	1584	4.2	0.12	13.9	1718	3.4	0.04	2.2	2982	18.8	0.05	3.4	3990	17.8	0.06	4.9	4152	16.5
		66	103	40	35	801	0.06	3.5	1473	5.9	0.09	7.8	1704	4.5	0.12	13.9	1848	3.7	0.04	2.2	3281	20.2	0.05	3.4	4287	19.6	0.06	4.9	4568	18.2
		74	129	43	38	898	0.06	3.5	1565	6.2	0.09	7.8	1810	4.8	0.12	13.9	1963	3.9	0.04	2.2	3543	21.5	0.05	3.4	4551	21.1	0.06	4.9	4933	19.6
		82	159	47	42	995	0.06	3.5	1647	6.6	0.09	7.8	1905	5.1	0.12	13.9	2066	4.1	0.04	2.2	3776	22.6	0.05	3.4	4787	22.6	0.06	4.9	5258	20.9
3000	E1	62	52	35	30	752	0.06	3.5	1286	5.1	0.09	7.8	1487	4.0	0.12	13.9	1613	3.2	0.04	2.2	2912	17.5	0.05	3.4	3705	17.4	0.06	4.9	4055	16.2
		74	73	41	36	898	0.06	3.5	1425	5.7	0.09	7.8	1648	4.4	0.12	13.9	1787	3.6	0.04	2.2	3184	19.1	0.05	3.4	4051	19.0	0.06	4.9	4434	17.6
		86	99	45	40	1043	0.06	3.5	1544	6.1	0.09	7.8	1785	4.8	0.12	13.9	1936	3.9	0.04	2.2	3421	20.5	0.05	3.4	4352	20.4	0.06	4.9	4764	18.9
		98	129	49	44	1189	0.06	3.5	1646	6.6	0.09	7.8	1904	5.0	0.12	13.9	2065	4.1	0.04	2.2	3631	21.8	0.05	3.4	4620	21.7	0.06	4.9	5056	20.1
		110	162	52	47	1334	0.06	3.5	1737	6.9	0.09	7.8	2010	5.3	0.12	13.9	2179	4.3	0.04	2.2	3820	22.9	0.05	3.4	4860	22.8	0.06	4.9	5319	21.2
3000	F1	75	48	39	34	910	0.06	3.5	1320	5.3	0.09	7.8	1527	4.1	0.12	13.9	1656	3.3	0.04	2.2	2929	17.7	0.05	3.4	3745	17.5	0.06	4.9	4078	16.2
		90	70	45	40	1092	0.06	3.5	1453	5.8	0.09	7.8	1681	4.5	0.12	13.9	1823	3.6	0.04	2.2	3203	19.3	0.05	3.4	4095	19.1	0.06	4.9	4460	17.8
		105	95	49	44	1274	0.06	3.5	1566	6.2	0.09	7.8	1811	4.8	0.12	13.9	1964	3.9	0.04	2.2	3438	20.7	0.05	3.4	4396	20.5	0.06	4.9	4787	19.1
		120	124	52	47	1456	0.06	3.5	1663	6.6	0.09	7.8	1924	5.1	0.12	13.9	2086	4.2	0.04	2.2	3644	22.0	0.05	3.4	4658	21.7	0.06	4.9	5073	20.2
		135	157	55	50	1638	0.06	3.5	1749	7.0	0.09	7.8	2024	5.4	0.12	13.9	2194	4.4	0.04	2.2	3826	23.1	0.05	3.4	4892	22.9	0.06	4.9	5328	21.2
3000	G1	86	50	41	36	1043	0.06	3.5	1331	5.3	0.09	7.8	1540	4.1	0.12	13.9	1670	3.3	0.04	2.2	3013	18.2	0.05	3.4	3852	18.0	0.06	4.9	4195	16.7
		104	72	47	42	1262	0.06	3.5	1476	5.9	0.09	7.8	1707	4.5	0.12	13.9	1851	3.7	0.04	2.2	3230	19.5	0.05	3.4	4130	19.3	0.06	4.9	4498	17.9
		122	100	51	46	1480	0.06	3.5	1597	6.4	0.09	7.8	1847	4.9	0.12	13.9	2003	4.0	0.04	2.2	3421	20.6	0.05	3.4	4374	20.4	0.06	4.9	4764	18.9
		140	131	54	49	1698	0.06	3.5	1701	6.8	0.09	7.8	1968	5.2	0.12	13.9	2134	4.2	0.04	2.2	3591	21.7	0.05	3.4	4592	21.4	0.06	4.9	5001	19.9
		158	167	58	53	1917	0.06	3.5	1793	7.1	0.09	7.8	2074	5.5	0.12	13.9	2249	4.5	0.04	2.2	3745	22.6	0.05	3.4	4788	22.4	0.06	4.9	5215	20.7
3000	H1	120	48	49	44	1456	0.06	3.5	1532	6.1	0.09	7.8	1772	4.7	0.12	13.9	1921	3.8	0.04	2.2	3184	18.9	0.05	3.4	4010	19.0	0.06	4.9	4433	17.6
		145	69	53	48	1759	0.06	3.5	1628	6.5	0.09	7.8	1883	5.0	0.12	13.9	2042	4.1	0.04	2.2	3380	20.1	0.05	3.4	4257	20.2	0.06	4.9	4706	18.7
		170	95	56	51	2062	0.06	3.5	1709	6.8	0.09	7.8	1977	5.3	0.12	13.9	2143	4.3	0.04	2.2	3550	21.1	0.05	3.4	4471	21.2	0.06	4.9	4943	19.7
		195	125	58	53	2365	0.06	3.5	1779	7.1	0.09	7.8	2057	5.5	0.12	13.9	2231	4.4	0.04	2.2	3700	22.0	0.05	3.4	4660	22.1	0.06	4.9	5152	20.5
		220	160	63	58	2669	0.06	3.5	1840	7.3	0.09	7.8	2128	5.7	0.12	13.9	2308	4.6	0.04	2.2	3834	22.8	0.05	3.4	4829	22.9	0.06	4.9	5338	21.3

**Performance table notes**

- 1) Air cooling capacities are based on Troom minus T primary air = 10 deg C. For other conditions multiply the table air cooling capacity by the required (Troom minus Tprimary air) divided by 10. Alternatively the air cooling capacity can be calculated from the formula: Air cooling capacity W = 1.213 x Airflow (l/s) x (Troom minus T primary air)
- 2) Water cooling capacities are based on 2 pipe chilled beams with Troom minus T entering water temperature = 10 deg C. For other conditions multiply the table water cooling capacity by the required (Troom minus T entering water) divided by 10.
- 3) Water heating capacities are based on 4 pipe chilled beams with T room minus T entering water temperature = 35 deg C. For other conditions multiply the table water heating capacity by the required (Troom minus T entering water) divided by 35.

## Selection example

### Specified data:

Office (LxWxH)	7.2 (L) x 5.4 (W) x 2.7 (H) m
Occupants:	4
Minimum Ventilation	4 x 10 l/s = 40 l/s
Preferred size of chilled beams	1800 x 600 mm ( 2 units )
Summer room design condition ( T <sub>room</sub> )	24 deg C with 50% Relative Humidity (dew point 13.0 deg C)
Chilled Water temperature ( T <sub>w,in</sub> )	15 deg C (Room Dew Point 13 deg C + 2 deg C)
Summer supply air temperature ( T <sub>1</sub> )	12 deg C
Summer sensible room cooling load	2700 W or 1350 W per chilled beam
Winter room design condition ( T <sub>room</sub> )	20 deg C with 50% Relative Humidity (dew point 9.0 deg C)
Heating water temperature ( T <sub>w,in</sub> )	45 deg C
Winter supply air temperature ( T <sub>1</sub> )	20 deg C
Winter heating requirement	2600 W or 1300 W per unit

### Calculation:

The temperature differences required to make the cooling selection are:

$$\Delta T_{AC} = T_{room} - T_1 = 24 - 12 = 12 \text{ deg C}$$

$$\Delta T_{WC} = T_{room} - T_{w,in} = 24 - 15 = 9 \text{ deg C}$$

The temperature differences required to make the heating selection are:

$$\Delta T_{AH} = T_1 - T_{room} = 20 - 20 = 0 \text{ deg C}$$

$$\Delta T_{WH} = T_{w,in} - T_{room} = 45 - 20 = 25 \text{ deg C}$$

Determine required airflow for humidity control:

$$\text{Room latent load} = 4 \text{ people} \times 55W = 220W$$

$$= 3.0 \times \text{Airflow l/s} \times \Delta \text{humidity g/kg}$$

Room condition 24 deg C 50% RH and humidity = 9.33 g/kg

Supply air condition 12 deg C. Allow 1 deg C heat gain for

AHU motor and duct heat gain so required off coil temp = 11 deg C and with 98% RH and humidity = 8.03 g/kg

Required primary airflow for humidity control

$$= 220 / [3.0 \times (9.33 - 8.03)] = 56 \text{ l/s or } 28 \text{ l/s per beam which is}$$

more than the 40l/s or 20l/s per beam required for ventilation

### Selection:

Model: Width:	600 mm
Length:	1800 mm
Performance table:	Page 9
Primary airflow:	28 l/s per beam
Nozzle:	B1
Static air pressure in plenum:	102 Pa

### Cooling Performance

Available cooling from primary air:

$$1.213 \times 28 \times 12 = 407 \text{ W per unit}$$

Required cooling from chilled water:

$$1350 - 407 = 943 \text{ W per unit}$$

From page 9 select water cooling capacity:

$$1062 \text{ W per unit at } \Delta T_{wc} = 10 \text{ deg C with water flow} = 0.08 \text{ l/s}$$

With  $\Delta T_{wc} = 9 \text{ deg C}$  water cooling equals:

$$1062 \times 9 \text{ deg C} / 10 \text{ deg C} = 956 \text{ W per unit}$$

and water flow is:

$$0.08 \text{ l/s}$$

water pressure drop is:

$$23.3 \text{ K pa}$$

water temperature difference is:

$$956 \text{ W} / (4.187 \times 0.08 \text{ l/s} \times 1000) = 2.9 \text{ deg C}$$

And total cooling capacity is:

$$407W + 956W = 1363W \text{ per unit} \times 2 \text{ units} = 2726 \text{ W}$$

This satisfies the total sensible cooling requirement of 2700 W for the room

### Heating Performance

Available heating from primary air:

$$1.213 \times 28 \times 0 = 0 \text{ W per unit}$$

Required heating from heating water:

$$1300 - 0 = 1300 \text{ W per unit}$$

From page 9 select water heating capacity

$$1889 \text{ W per unit at } \Delta T_{wh} = 35 \text{ deg C with water flow} = 0.03 \text{ l/s}$$

So water heating capacity for  $\Delta T_{wc} = 25 \text{ deg C}$

$$1889 \times 25 \text{ deg C} / 35 \text{ deg C} = 1349 \text{ W per unit}$$

and water flow is:

$$0.03 \text{ l/s}$$

water pressure drop is:

$$0.9 \text{ K pa}$$

water temperature difference is:

$$1349 \text{ W} / (4.187 \times 0.03 \text{ l/s} \times 1000) = 10.7 \text{ deg C}$$

So total heating capacity is:

$$0W + 1349W = 1349 \text{ W} \times 2 \text{ unit} = 2698 \text{ W per unit}$$

This satisfies the total sensible heating requirement of 2600 W

For non standard applications and/or selections, please contact our technical staff.

## Guide Specifications

Barcol-Air KLIMA 600 series active chilled beams shall be used to compensate for the external and internal heat loads of the building and shall maintain the thermal comfort in the room within the specified comfort and noise criteria.

### Functional description

- Primary air will be supplied by the fresh air handling unit to the chilled beam air plenum box. The primary air shall then pass through the induction nozzles into the mixing section to mix with the induced room air before being distributed into the room by two slot diffusers.
- Induction nozzles shall induce air from the room through the inlet air diffuser and then through the fin and tube cooling/heating heat exchanger before mixing with the primary air and being supplied to the room. The induction nozzles shall be factory installed to provide the required unit capacity with the specified primary airflow, air inlet pressure and noise level.
- Heat exchangers shall be 2-pipe type for cooling only or cooling/heating changeover systems or 4 pipe type for systems with separate cooling and heating circuits.
- The units shall incorporate two linear slot air supply diffusers and shall be designed so that the supply air is discharged horizontally under the ceiling using the "Coanda" effect to increase the air throw and to ensure the air mixing with the room air above the occupied zone. The centre diffuser shall be perforated to allow the room air to flow in to the heat exchanger and shall be easily removable to allow for any accumulated dust to be removed from the heat exchanger with a vacuum cleaner. The centre diffuser shall be provided with safety hanging wires.

### Construction of the chilled beam:

- The primary air plenum box shall be manufactured from galvanized sheet steel and shall have one or more circular air spigot connectors to ensure the inlet air velocity does not exceed 2.5 m/s. The plenum should be internally insulated to prevent condensation if the primary supply air temperature is less than the surrounding air dew point temperature.
- The nozzle plate and chilled beam body shall be manufactured from galvanized steel with a minimum thickness of 0.8mm.
- The heat exchangers shall be made from seamless copper tubes with aluminum fins and shall have 12 or 15 mm diameter water connections depending on unit's size and connections. The heat exchangers shall be suitable to operate at 15 bar working pressure and shall be factory pressure tested at 20 bar pressure.
- The supply air diffuser and room air inlet diffuser shall be manufactured from galvanized steel with a minimum thickness of 1.0 mm and shall be finished with polyester powder paint to RAL9010 with 20% gloss or with an alternative finish to be specified.

### Dimensions

Width: The chilled beam shall be 595 mm wide.

Length: The units shall be 1200, 1500, 1800, 2400 and 3000 mm long or any intermediate length by special order.

Height: The height of the chilled beam (including distribution plenum) shall not be more than 200mm.

### Installation

The chilled beam shall have 7 mm diameter mounting holes for suspension by 6mm diameter threaded rod or suspension wires.



Website: [www.barcolair.net](http://www.barcolair.net)